

ZEXEL - TEST VALUES
Injection pumps

BOSCH No. : 9 400 610 138 1/3
ZEXEL No. : 101402-0510
Date : 31.01.1990 [0]
Company : ISUZU
Engine : 4BD1 / 5-15601-422-1

IP-Type number : 101040-8370 / PES4A
Governor type number : 105410-6900 / EP/RSV

TEST PREREQUISITES

Test oil : ISO-4113
Test oil inlet temperature °C : 40.00...45.00
Inlet pressure bar : 1.6
Test nozzle holder combination : 1 688 901 013
Opening pressure bar : 175
Test pressure line
Inner x Outer Dia - Length mm : 2.00 x 6.00 x 600

PORT CLOSING

Prestroke mm : 3.6 ± 0.05
Rod position mm : -
Port closing mark Cyl. No. : -
Cam sequence : 1 - 3 - 4 - 2

Port closing mark Cyl. No. : -
Port closing difference °NW : 0-90-180-270

Tolerance +- °C: 0.50 (0.75)

A1

ZEXEL - Test values
Injection pumps



Injection Quantity :

Adjusting Point	Rack Position (mm)	Pump Speed (r.p.m)	Injection Q'ty (cc/1000 str.)	Difference (%)	Fixed	Remarks
A	9.5	1200	51.9 - 54.9	± 2	Rack	Basic
B	approx. 7.9	325	8.2 - 11.0	± 14	Rack	
A	9.5	1200	51.9 - 54.9	-	Lever	Basic

Timing Advance Specification :

Pump Speed (r.p.m)							
Advance Angle (deg.)							

A2

ZEXEL - Test values
Injection pumps



A3

ZEXEL - Test values
Injection pumps



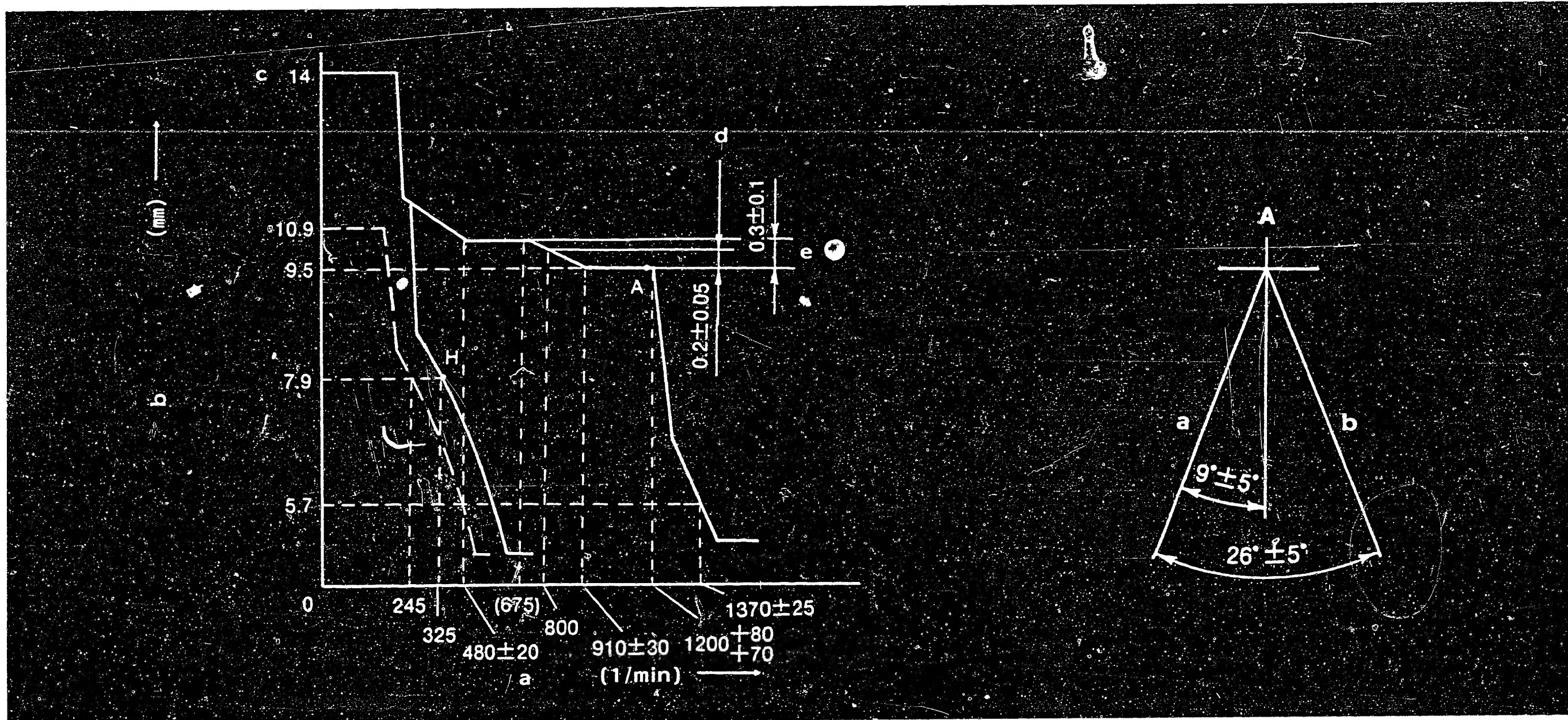

Figure 1

GOVERNOR ADJUSTMENT

- a = Pump speed
- b = Control rack position
- c = above
- d = Difference in control rack position between 1200 rpm and 800 rpm
- e = Difference in control rack position between 1200 rpm and 600 rpm

A = Control lever angle

a = Full-speed
b = Idling

Note

- Before adjustment, remove the idling sub spring and the torque control spring.
- Move the control lever fully in the stop direction, and set the minimum-speed stopper bolt so that the control rack position is 0.5 - 1.0 mm.



■ ADJUSTMENT

	Pump speed (rpm)	Rack position (mm)	Remarks
Full-load Adjustment (Temporary)	1270 - 1280 1100	9.5 9.5	<ul style="list-style-type: none"> • Adjust using screw (1) • Adjust using screw (2)
Torque Control spring Adjustment	600 (675) 800 880 - 940	9.8 9.8 9.7 9.5	<ul style="list-style-type: none"> • Adjust using spring capsule (4) • Confirm • Confirm • Confirm the torque control stroke is 0,3 mm
Idling Adjustment	325 0 245 -	approx. 7.9 - approx. 7.9 -	<ul style="list-style-type: none"> • Adjust using screw (3) • Freely position the control lever • Adjust using spring caps. (5) • Confirm
Maximum-speed Adjustment	1270 - 1280 1285 - 1335 1350 -	9.5 5.7 0.1 - 0.6 -	<ul style="list-style-type: none"> • Adjust using screw (1) • Confirm speed droop • Confirm • Confirm
Full-load Adjustment (Install the cover on governor cover)	1200	9.5	<ul style="list-style-type: none"> • Adjust using screw (2)
Control Lever Angle Measurement	<ul style="list-style-type: none"> • Measure the control lever angle at the "idling" and "full" positions. • When the control lever is depressed toward the "full" position, replace the shifter's shim with a thicker one. • When the control lever is depressed toward the "idling" position, replace the shifter's shim with a thinner one. 		
Rack Limiter Adjustment	-	-	

A6

ZEXEL - Test values
Injection pumps

A7

ZEXEL - Test values
Injection pumps

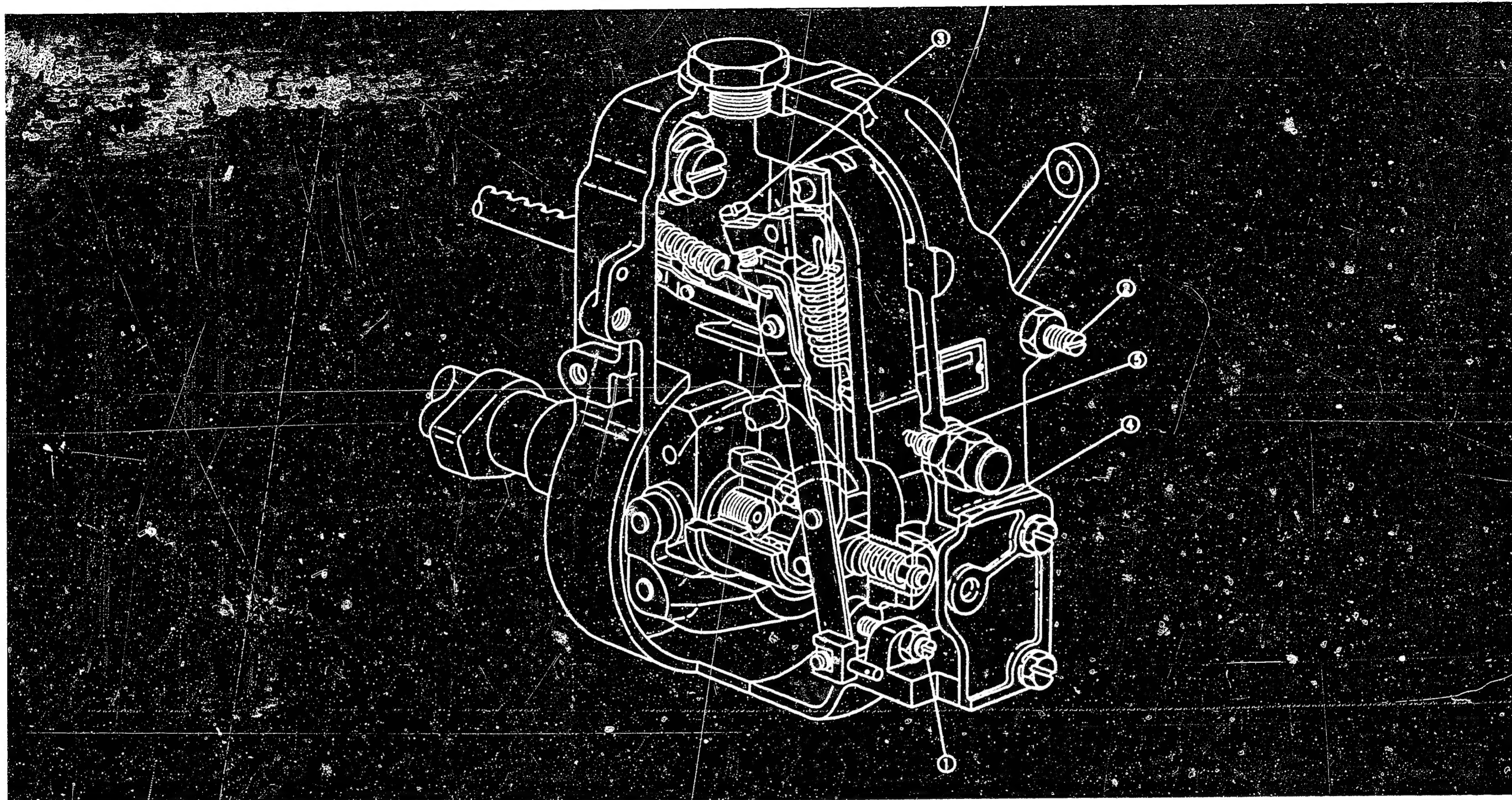

Figure 2

101402-0510 3/3

- 1 = Screw
- 2 = Screw
- 3 = Screw
- 4 = Spring capsule
- 5 = Spring capsule

A8

ZEXEL - Test values
Injection pumps



A9

ZEXEL - Test values
Injection pumps



ZEXEL - TEST VALUES
Injection pumps

BOSCH No.	:	9 400 610 141	1/4
ZEXEL No.	:	101402-3471	
Date	:	31.01.1991	[2]
Company	:	KOMATSU	
Engine	:	S4D105 /6131-72-1411	

IP-Type number : 101040-8090 / PES4A
Governor type number : 105400-1380 / EP/RSV

TEST PREREQUISITES

Test oil : ISO-4113
Test oil inlet temperature °C : 40.00...45.00
Inlet pressure bar : 1.6
Test nozzle holder combination : 1 688 901 013
Opening pressure bar : 175
Test pressure line
Inner x Outer Dia - Length mm : 2.00 x 6.00 x 600

PORT CLOSING

Prestroke mm : 3.5 ± 0.05
Rod position mm : -
Port closing mark Cyl. No. : -
Cam sequence : 1 - 2 - 4 - 3

Port closing mark Cyl. No. : -
Port closing difference °NW : 0-90-180-270

Tolerance +- °C: 0.50 (0.75)

A10

ZEXEL - Test values
Injection pumps



Injection Quantity :

Adjusting Point	Rack Position (mm)	Pump Speed (r.p.m)	Injection Q'ty (cc/1000 str.)	Difference (%)	Fixed	Remarks
A	10.4	1200	80.0 - 84.0	± 2	Rack	Basic
C	approx. 5.3	400	10.5 - 14.5	± 4	Rack	
A	10.4	1200	80.0 - 84.0	-	Lever	Basic
B	10.4	700	69.0 - 77.0	-	Lever	

Timing Advance Specification :

Pump Speed (r.p.m)							
Advance Angle (deg.)							



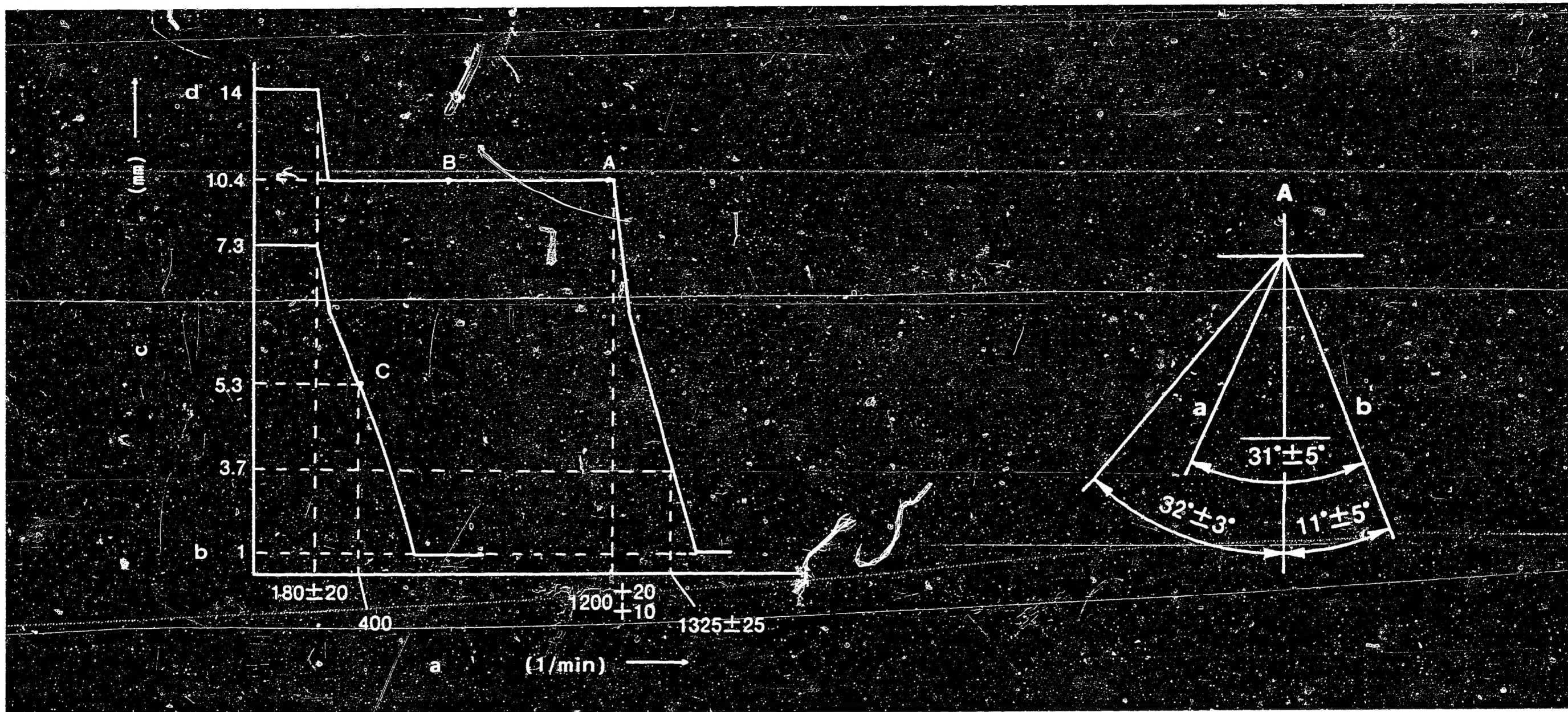

Figure 3

GOVERNOR ADJUSTMENT

101402-3471 2/4

- a = Pump speed
- b = below
- c = Control rack position
- d = above

A = Control lever angle

- a = Idling
- b = Full-speed

Note

- Before adjustment, remove the idling sub spring and the torque control spring.
- Move the control lever fully in the stop direction, and set the minimum-speed stopper bolt so that the control rack position is 0.5 - 1.0 mm.



■ ADJUSTMENT

	Pump speed (rpm)	Rack position (mm)	Remarks
Full-load Adjustment (Temporary)	1200 700	10.4 10.4	<ul style="list-style-type: none"> • Adjust using screw (1) • Confirm
Torque Control spring Adjustment			<ul style="list-style-type: none"> • Adjust using spring capsule (4) • Confirm • Confirm • Confirm the torque control stroke
Idling Adjustment	0 400 -	7.3 5.3 -	<ul style="list-style-type: none"> • Adjust using screw (3) • Adjust using spring capsule (5) • Confirm
Maximum-speed Adjustment	1210 - 1220 1300 - 1350	10.4 3.7	<ul style="list-style-type: none"> • Adjust using screw (1) • Confirm speed droop • Confirm • Confirm
Full-load Adjustment (Install the cover on governor cover)	700	10.4	<ul style="list-style-type: none"> • Adjust using screw (2)
Control Lever Angle Measurement	<ul style="list-style-type: none"> • Measure the control lever angle at the "idling" and "full" positions. • When the control lever is depressed toward the "full" position, replace the shifter's shim with a thicker one. • When the control lever is depressed toward the "idling" position, replace the shifter's shim with a thinner one. 		
Rack Limiter Adjustment	-	-	

A15

ZEXEL - Test values
Injection pumps

A16

ZEXEL - Test values
Injection pumps

Control lever adjustment

1. Push the control lever (1) in the "STOP" direction until it contacts the guide screw (2).
2. Set the control rack position to 0.2 - 2.0 mm by altering the guide screw position or by changing the shim thickness (4).
3. When the control lever has been pushed in the "STOP" direction, check that it returns to the idling position when released.

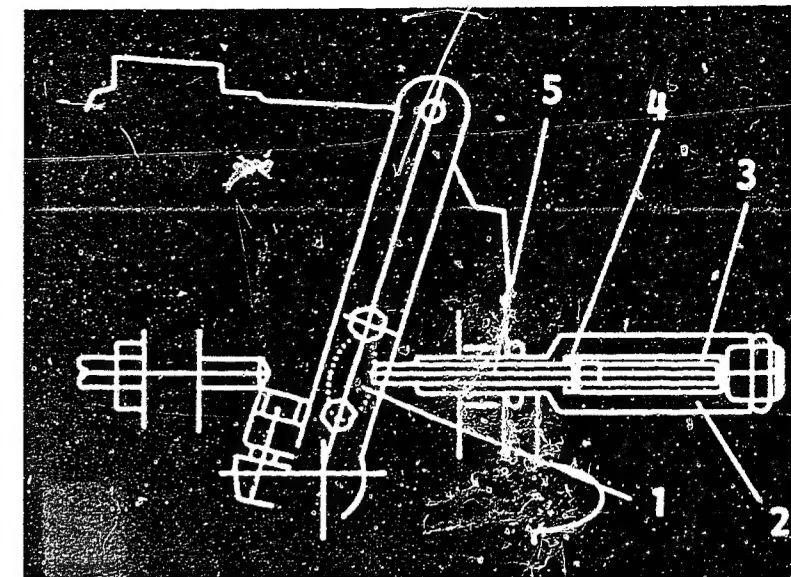

Figure 4

- 1 = Control rod
- 2 = Guide screw
- 3 = Spring
- 4 = Shim
- 5 = Push rod

Shim Part No.	Thickness (mm)
029310-5180	0,10
029310-5210	0,15
029310-5030	0,20
029310-5220	0,25
029310-5040	0,30
029310-5050	0,50
029310-5060	0,10



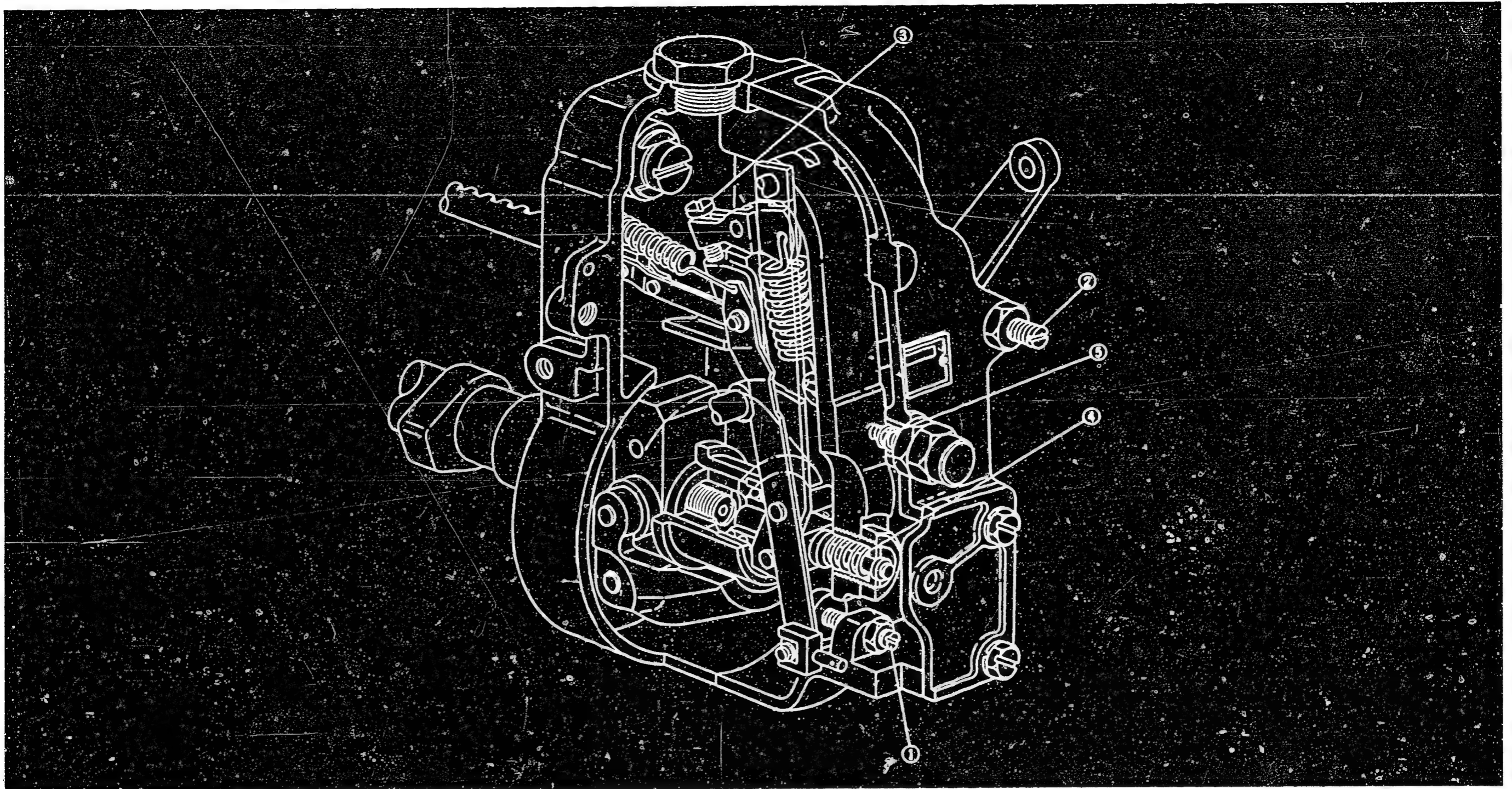

Figure 5

101402-3471 4/4

- 1 = Screw
- 2 = Screw
- 3 = Screw
- 4 = Spring capsule
- 5 = Spring capsule

A19

ZEXEL - Test values
Injection pumps



A20

ZEXEL - Test values
Injection pumps



ZEXEL - TEST VALUES
Injection pumps

BOSCH No.	:	9 400 610 140	1/4
ZEXEL No.	:	101491-9095	
Date	:	31.01.1991	[6]
Company	:	MAZDA	
Engine	:	SL-D / SL10-13-800E	
IP-Type number	:	101049-9450 / PES4A	
Governor type number	:	105921-2980 / EP/RLD	

TEST PREREQUISITES

Test oil	:	ISO-4113
Test oil inlet temperature °C	:	40.00...45.00
Inlet pressure bar	:	1.6
Test nozzle holder combination	:	1 688 901 013
Opening pressure bar	:	175
Test pressure line	:	
Inner x Outer Dia - Length mm	:	2.00 x 6.00 x 600

PORT CLOSING

Prestroke mm	:	3.4 ± 0.05
Rod position mm	:	-
Port closing mark Cyl. No.	:	-
Cam sequence	:	1 - 3 - 4 - 2
Port closing mark Cyl. No.	:	-
Port closing difference °NW	:	0-90-180-270
Tolerance +- °C	:	0.50 (0.75)

B1

ZEXEL - Test values

Injection pumps



Injection Quantity :

Adjusting Point	Rack Position (mm)	Pump Speed (r.p.m)	Injection Q'ty (cc/1000 str.)	Difference (%)	Fixed	Remarks
	11.21±0.2	1000	56.3 - 57.3	± 2	Rack	Basic
H	approx. 9.6	325	7.0 - 11.0	± 14	Rack	
A	(11.21)	1000	56.3 - 57.3	-	Lever	Basic
B	(11.48)	1700	66.9 - 70.9	-	Lever	
C	(11.32)	625	40.0 - 44.0	-	Lever	
I	above 15	100	96.0 - 116.0	-	Lever	

Timing Advance Specification : EP/SCDM
105670-0080

Pump Speed (r.p.m)	1325 - 1370	1700					
Advance Angle (deg.)	Start	Finish 3.2-3.8					

B2

ZEXEL - Test values
Injection pumps



B3

ZEXEL - Test values
Injection pumps



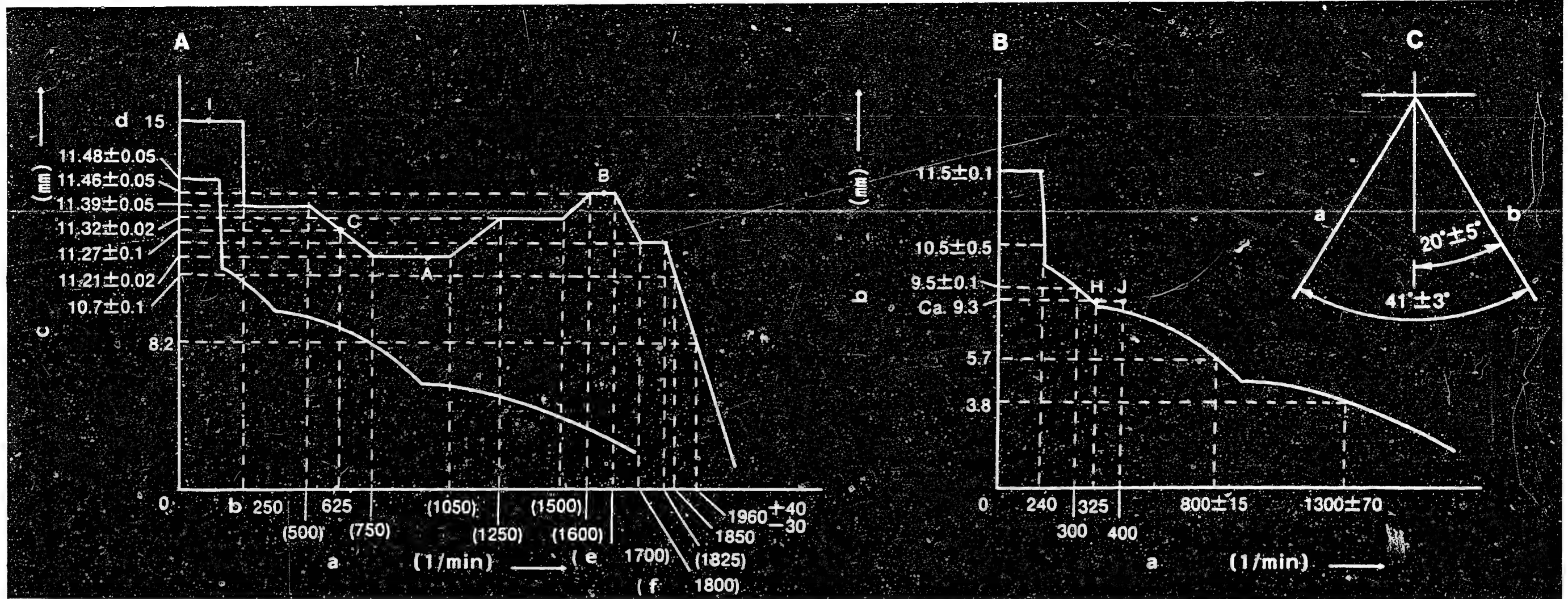

Figure 6

GOVERNOR ADJUSTMENT

101491-9095 2/4

A = FULL ADJUSTMENT

B = IDLE ADJUSTMENT

C = Control lever angle

a = Pump speed

a = Pump speed

a = Full-speed

b = below

b = Control rack position

b = Idling

c = Control rack position

d = above

e = above

f = below

B4

ZEXEL - Test values
Injection pumps



B5

ZEXEL - Test values
Injection pumps



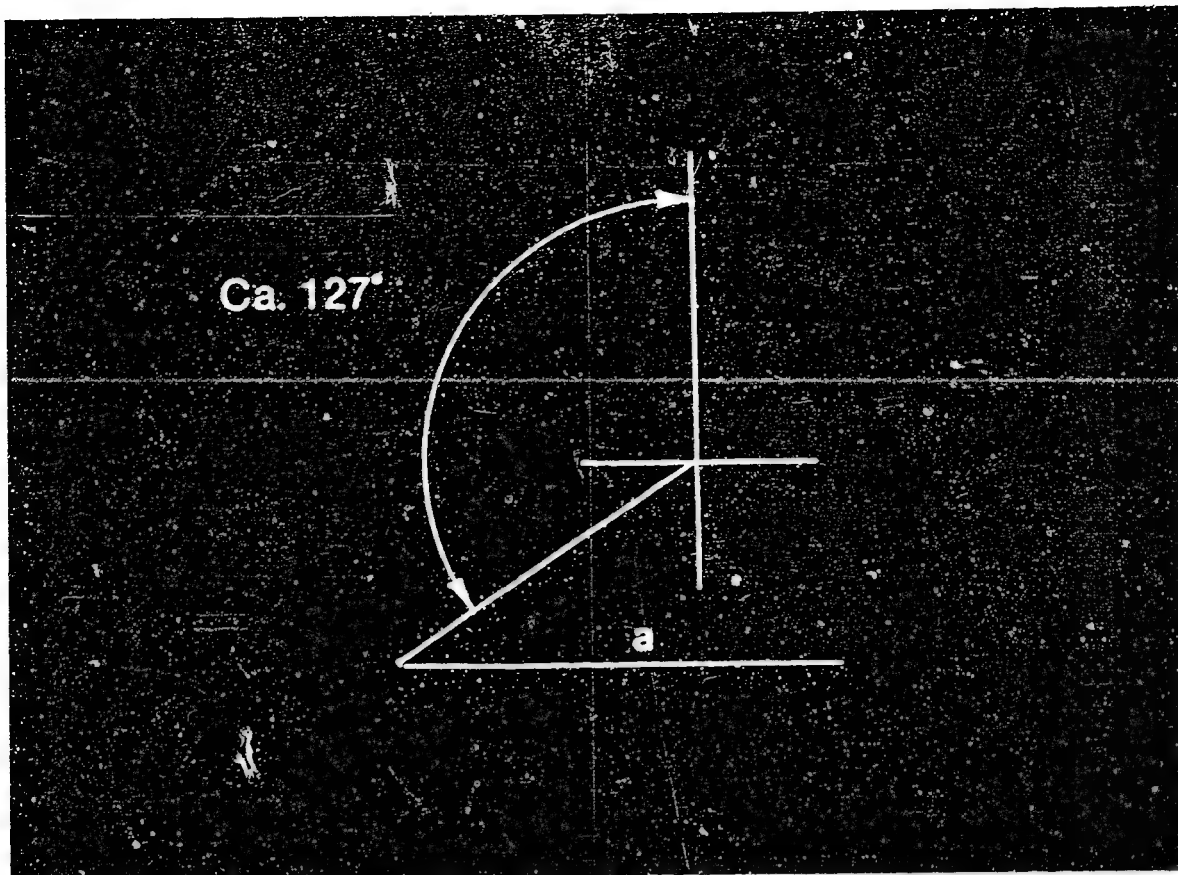

Figure 7

101491-9095 2/4

Pump center line

a = Mark "CC"

■ TIMING SETTING

At No. 1 plunger's beginning of injection position.

B.T.D.C.: 12°

B6

ZEXEL - Test values
Injection pumps



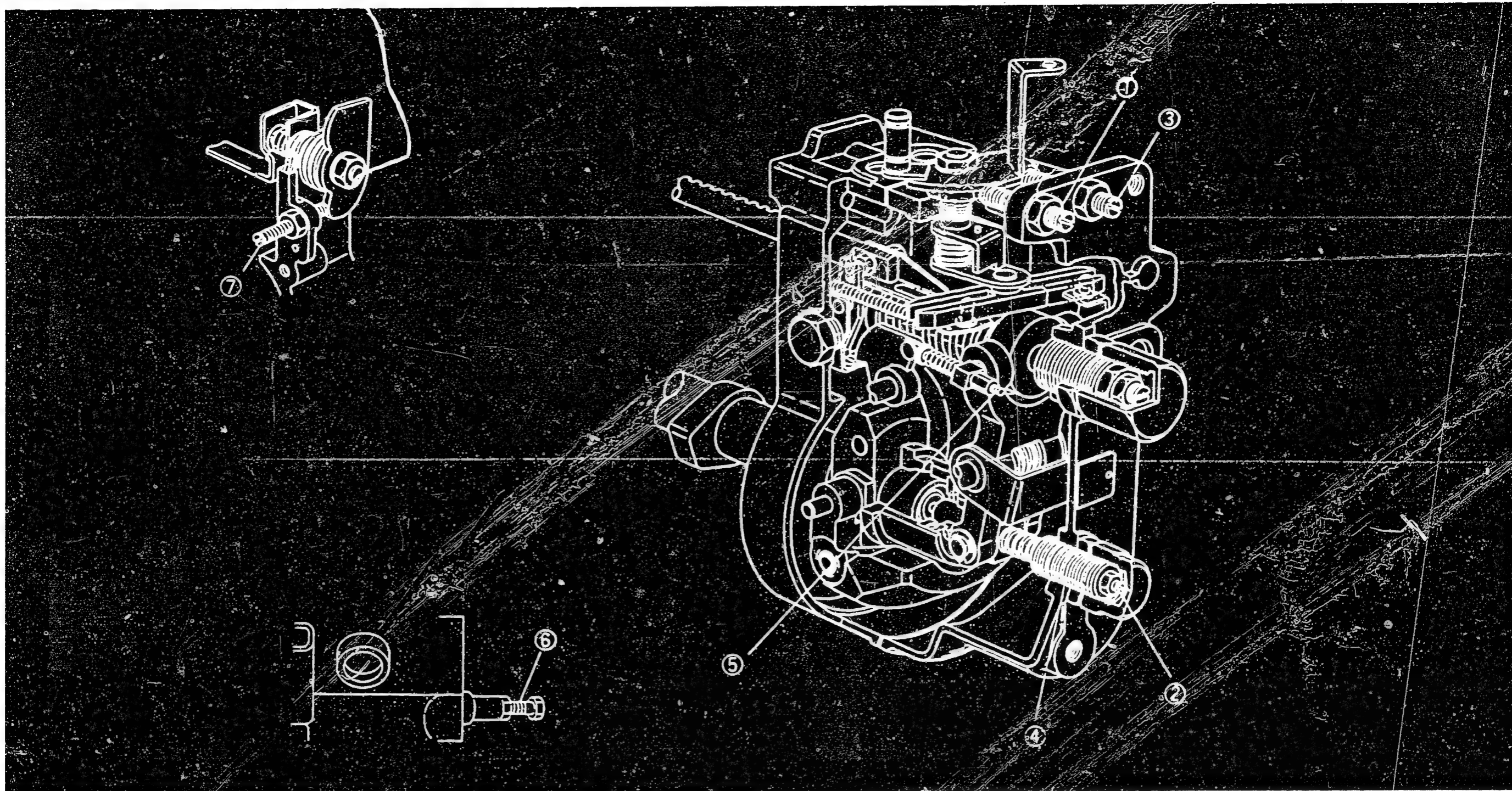

Figure 8

101491-9095 3/4

- 1 = Screw
- 2 = Screw
- 3 = Screw
- 4 = Spring capsule

- 5 = Screw
- 6 = Screw
- 7 = Screw

B7

ZEXEL - Test values
Injection pumps



B8

ZEXEL - Test values
Injection pumps



IDLING ADJUSTMENT

	Pump speed (rpm)	Rack position (mm)	Remarks
Idling Lever Position Temporary Setting	80 - 100	11.4 - 11.6	• Adjust using screw (1)
Idling Position Setting	300	9.4 - 9.6	• Adjust using spring capsule (4)
	240	10.0 - 11.0	• Adjust using screw (2)
Governor Spring Contact Adjustment	785 - 815	5.7	• Adjust the governor shaft position
	1230 - 1270	3.8	• Confirm
Setting the Idling Lever Position	325	approx. 9.3	• Adjust using screw (1) • Confirm the control lever angle (15 - 25°)

B9
 ZEXEL - Test values
 Injection pumps
**B10**
 ZEXEL - Test values
 Injection pumps

	Pump Speed (r.p.m)	rack Position (mm)	Remarks
Full Speed Lever Position Temporary Setting	approx. 1800	approx. 11.27	• Adjust using screw (3)
Full Load Position Adjustment	1000	11.19 - 11.23	• Adjust using screw (7)
Torque Cam Position Adjustment	625	11.30 - 11.34	• Adjust using screw (5)
	450	11.41 - 11.51	• Confirm
	1400	11.34 - 11.44	• Confirm
	1700	11.43 - 11.53	• Confirm
	1800	11.17 - 11.37	• Confirm
Confirm injection quantity at points A to C			
Maximum Speed Control Adjustment	1850	10.63 - 10.83	• Adjust using screw (3)
	1930 - 2000	8.2	• Confirm • After adjustment confirm that the control lever angle is 38° - 44°
Confirming Excess Fuel Limit for Engine Starting	400	approx. 9.3	• Set the control lever at point J
	0	11.4 - 11.6	• Confirm
	0	above 15	• Move the control lever to the "full-speed" position and then confirm the control rack position
Confirm the Black Smoke Limit	Fix the control lever at point H. Then operate the pump at 250 rpm. Confirm that the control rack does not move beyond 11.46 mm. When the control lever is moved to the "full-speed" position again increase the pump speed and confirm that the control rack starts to move from a pump speed of (500) rpm.		
Rack Limiter Adjustment			• Fix the control rack
	<ul style="list-style-type: none"> • Measure the depth of the control rack cap. Then adjust screw (6) so that it equals the depth of the rack cap and install the rack cap. • Confirm injection quantities. 		



ZEXEL - TEST VALUES
Injection pumps

BOSCH No.	:	9 400 610 127	1/3
ZEXEL No.	:	104303-2770	
Date	:	31.01.1991	[1]
Company	:	ISEKI	
Engine	:	E3AE1-B07K - 6215600-0430A	

IP-Type number : 104300-6510 / PES3K
Governor type number : -

TEST PREREQUISITES

Test oil : ISO-4113
Test oil inlet temperature °C : 40.00...45.00
Inlet pressure bar : 1.6
Test nozzle holder combination : 1 688 901 013
Opening pressure bar : 175
Test pressure line
Inner x Outer Dia - Length mm : 2.00 x 6.00 x 600

PORT CLOSING

Prestroke mm : 2.1 ± 0.05
Rod position mm : -
Port closing mark Cyl. No. : -
Cam sequence : 1 - 3 - 2

Port closing mark Cyl. No. : -
Port closing difference °NW : 0-120-240

Tolerance +- °C: 0.50 (0.75)

B13

ZEXEL - Test values
Injection pumps



Continued (Test values)

Injection Quantity :

Adjusting Point	Rack Position (mm)	Pump Speed (r.p.m)	Injection Q'ty (cc/1000 str.)	Difference (%)	Fixed	Remarks
A	9.7	800	(23.6 - 27.6)	± 4	Lever	Basic
B	8.8	1250	25.6 - 27.6	± 2.5	Lever	
C	approx. 6.1	425	6.5 - 8.5	± 14	Lever	
D	13 - 14	100	above 35.0	-	Lever	

Timing Advance Specification :

Pump Speed (r.p.m)							
Advance Angle (deg.)							

B14

ZEXEL - Test values
Injection pumps



B15

ZEXEL - Test values
Injection pumps



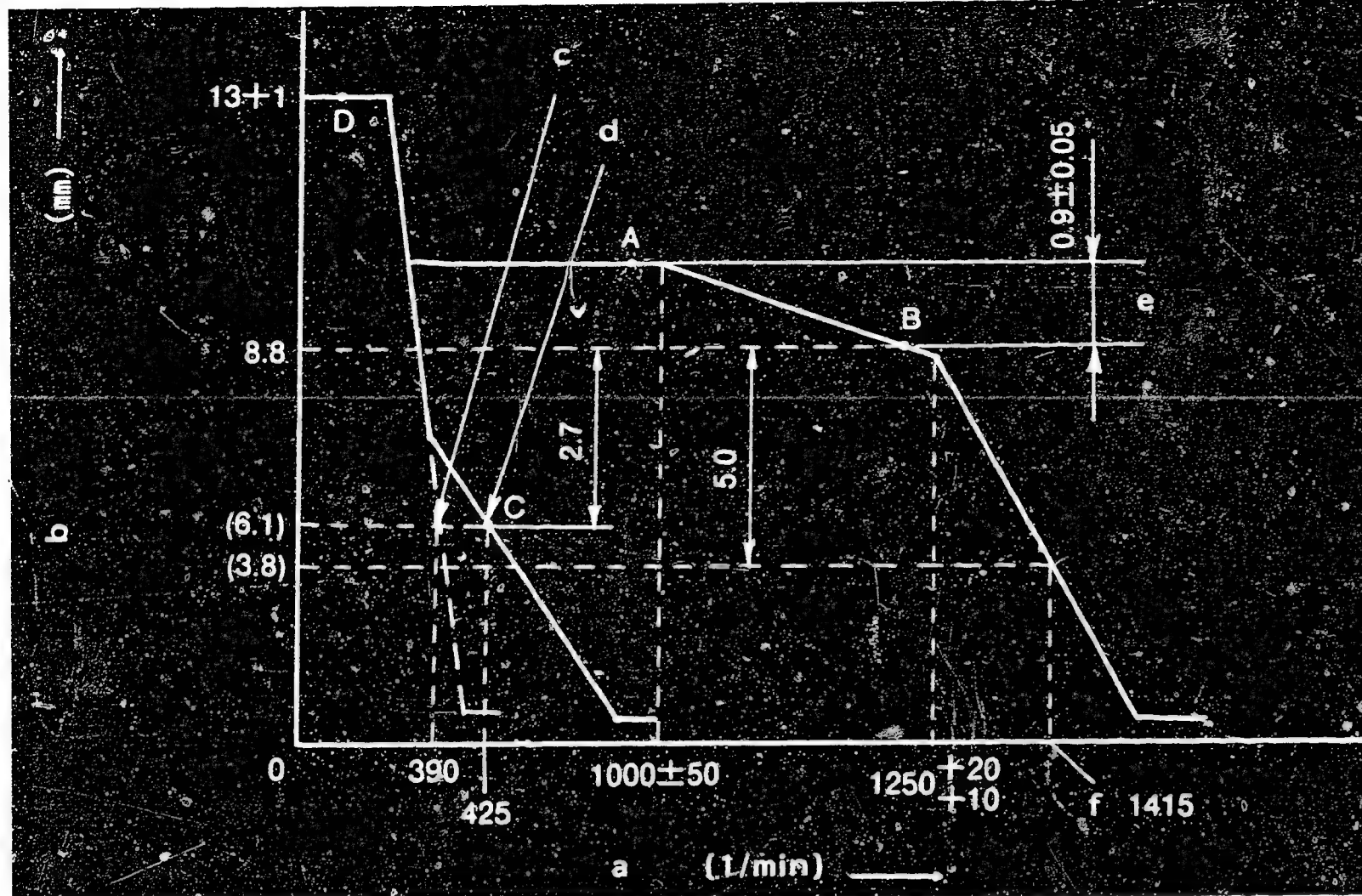

Figure 9

- a = Pump speed
- b = Control rack position
- c = Idle spring setting
- d = Main spring set
- e = Difference in control rack position between 1250 rpm and 800 rpm
- f = below

■ TIMING SETTING

At No. 1 plunger's beginning of injection position.

B.T.D.C.: 20°

GOVERNOR ADJUSTMENT

- A = Control lever angle
- a = Full-speed
- b = Idling

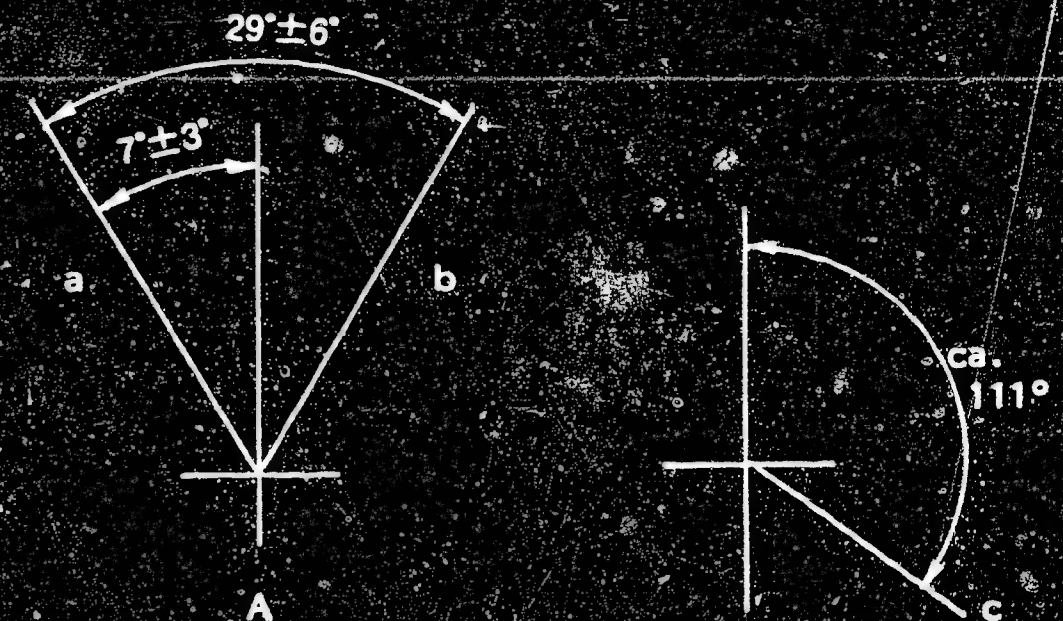

Figure 10

- Pump center line
- c = Mark "oo"



	Pump speed (r.p.m)	Rack position (mm)	Remarks
Full load adjustment (temporary)	1250 1250	8.8 - 8.9 8.8 - 8.9	<ul style="list-style-type: none"> • Adjust using screw (1) • Confirm injection quantity at point "B" • Confirm control lever angle (4 - 10°)
Maximum speed adjustment	Fix the control lever in the full-speed position		
	below 1415 1260 - 1270	(3.8) (8.8)	<ul style="list-style-type: none"> • Confirm • Adjust using screw (2)
Idling adjustment	390 425 0	(6.1) (6.1) 13+1	<ul style="list-style-type: none"> • Adjust using idling spring guide (5) • Move the control lever • Confirm
Stopper bolt adjustment	100	(6.1)	<ul style="list-style-type: none"> • Adjust using screw (3)
Torque control spring adjustment	1260 - 1270 1250 950 - 1050	8.8 - 8.9 8.8 9.7	<ul style="list-style-type: none"> • Move the control lever • Confirm • Adjust using screw (4) • Confirm that torque control stroke = 0,9 mm

B18

ZEXEL - Test values
Injection pumps



B19

ZEXEL - Test values
Injection pumps



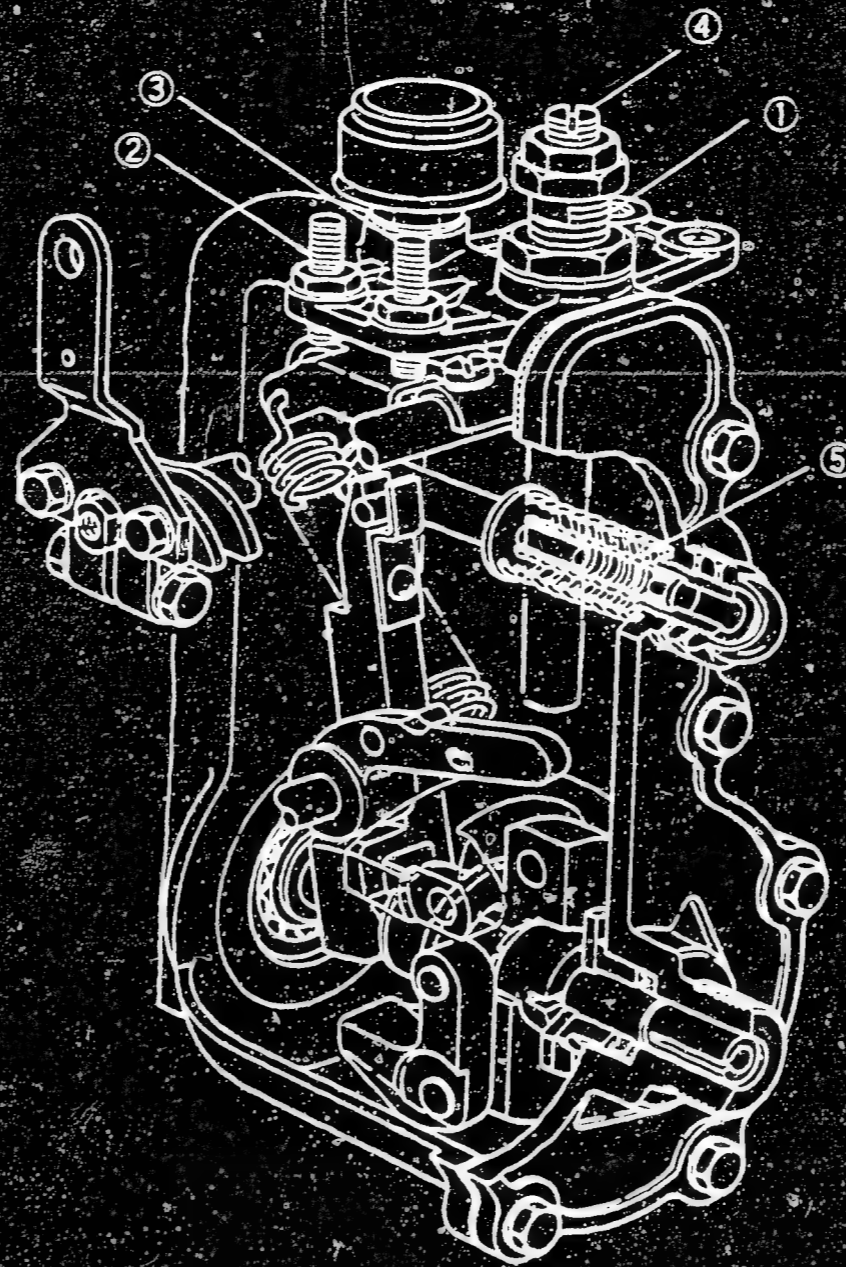

Figure 11
1 = Screw
2 = Screw
3 = Screw
4 = Screw
5 = Spring capsule
(Idling spring guide)

104303-2770 3/3

B 20

ZEXEL - Test values
Injection pumps



B 21

ZEXEL - Test values
Injection pumps



ZEXEL - TEST VALUES

Injection pumps

BOSCH No.	: 9 400 610 128	1/3
ZEXEL No.	: 104303-2780	
Date	: 31.01.1991	[2]
Company	: ISEKI	
Engine	: E3AF1-B01K - 6215600-0560A	

IP-Type number	: 104300-6520 / PES3K
Governor type number	: -

TEST PREREQUISITES

Test oil	: ISO-4113
Test oil inlet temperature °C	: 40.00...45.00
Inlet pressure bar	: 1.6
Test nozzle holder combination	: 1 688 901 013
Opening pressure bar	: 175
Test pressure line	
Inner x Outer Dia - Length mm	: 2.00 x 6.00 x 600

PORT CLOSING

Prestroke	mm	: 2.1 ± 0.05
Rod position	mm	: -
Port closing mark Cyl. No.		: -
Cam sequence		: 1 - 3 - 2
Port closing mark Cyl. No.		: -
Port closing difference °NW		: 0-120-240
Tolerance	+ - °C	: 0.50 (0.75)



Injection Quantity :

Adjusting Point	Rack Position (mm)	Pump Speed (r.p.m)	Injection Q'ty (cc/1000 str.)	Difference (%)	Fixed	Remarks
A	8.6	1250	22.4 - 24.4	± 2.5	Lever	Basic
B	approx. 7.1	425	6.5 - 8.5	± 14	Lever	
C	13.0 ^{+1.0}	100	above 43.0	-	Lever	
D	9.6	800	(22.4)	-	Lever	

Timing Advance Specification :

Pump Speed (r.p.m)							
Advance Angle (deg.)							



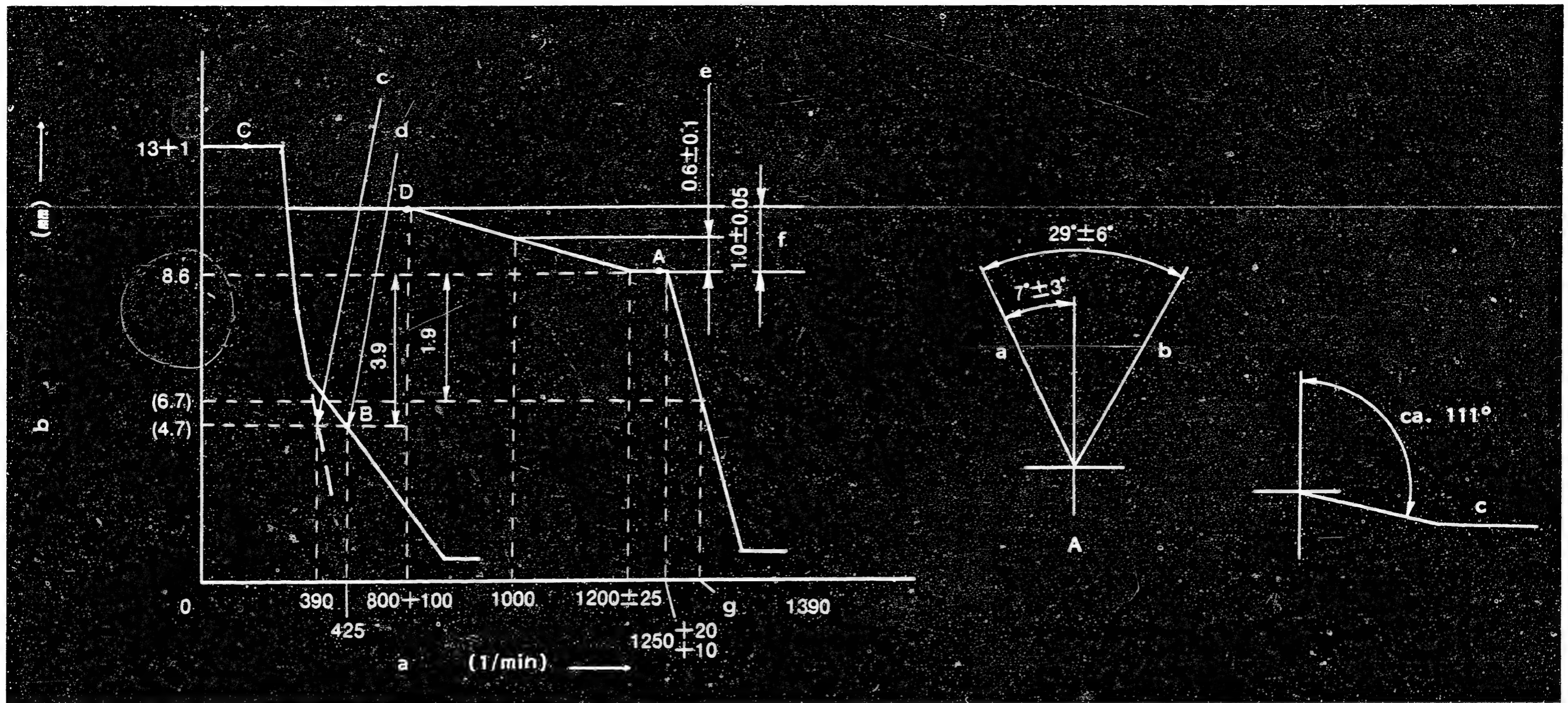

Figure 12

GOVERNOR ADJUSTMENT

104303-2780 2/3

- a = Pump speed
- b = Control rack position
- c = Idle spring setting
- d = Main spring set
- e = Difference in control rack position between 1250 rpm and 1000 rpm
- f = Difference in control rack position between 1250 rpm and 800 rpm
- g = below

- A = Control lever angle
- a = Full-speed
- b = Idling

- Pump center line
- c = Mark "oo"

■ TIMING SETTING
 At No. 1 plunger's beginning of injection position.
 B.T.D.C.: 18°

	Pump speed (r.p.m)	Rack position (mm)	Remarks
Full load adjustment (temporary)	1250 1250	8.6 8.6	<ul style="list-style-type: none"> • Adjust using screw (1) • Confirm injection quantity at point "A" • Confirm control lever angle (4 - 10°)
Maximum speed adjustment	Fix the control lever in the full-speed position		
	below 1390 1260 - 1270	(6.7) 8.6	<ul style="list-style-type: none"> • Confirm • Adjust using screw (2)
Idling adjustment	390 425 1250 0	(4.7) (4.7) 8.6 13+1	<ul style="list-style-type: none"> • Adjust using idling spring guide (5) • Move the control lever • Confirm injection quantity at point "A" • Confirm
Stopper bolt adjustment	100	(4.7)	<ul style="list-style-type: none"> • Adjust using screw (3)
Torque control spring adjustment	1260 - 1270 800 - 900 1000 1175 - 1225	8.6 9.6 9.2 8.6	<ul style="list-style-type: none"> • Move the control lever • Adjust using screw (4) • Confirm • Adjust torque control stroke (1 mm) using shims • Confirm that torque control stroke = 1.0 mm

C6

ZEXEL - Test values
Injection pumps



C7

ZEXEL - Test values
Injection pumps



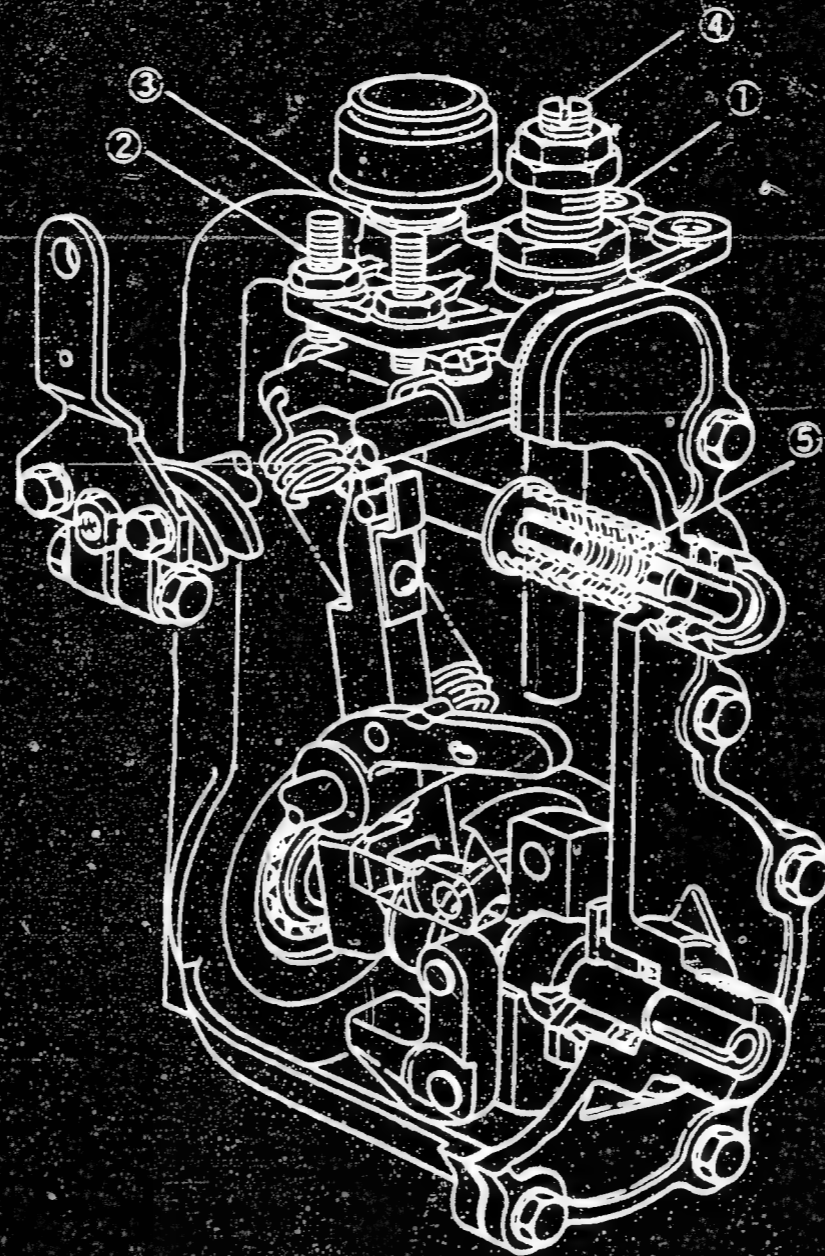

Figure 13
1 = Screw
2 = Screw
3 = Screw
4 = Screw
5 = Spring capsule
(Idling spring guide)

104303-2780 3/3

C8

ZEXEL - Test values
Injection pumps



C9

ZEXEL - Test values
Injection pumps



Test oil
ISO 4113 or
SAE J967d

ZEXEL - TEST VALUES
Distributor pumps
Engine model: 4D55

1/2

BOSCH No.	9 460 610 096
ZEXEL No.	104740-3541
Date:	31.01.1991 [0]
Company:	mitsubishi
No.	MD077643

Injection pump no.: 104640-3271

(NP-VE4/10F2100RNP258)

Pump rot.: Clockwise-viewed from drive side

Test-nozzle holder combination:
1 688 901 000

Test pressure line:
1 680 750 017

1. Setting values	Speed (rpm)	Setting values	Charge-air pressure bar (mmHg)	Difference in delivery (cc)
1-1 Timing device travel	1250	3.1 - 3.5 (mm)	0	
1-2 Supply pump pressure	1250	4.5 - 5.1 (kg/cm ²)	0	
1-3 Full load delivery	600	35.7 - 36.7 (cc/1000st)	0	3.0
Full load delivery		- (cc/1000st)		
1-4 Idle speed regulation	375	6.5 - 9.5 (cc/1000st)	0	2.0
1-5 Start	100	63.0 - 83.0 (cc/1000st)	0	
1-6 Full-load speed regulation	2650	16.6 - 22.6 (cc/1000st)	510 - 530	5.5
1-7 Full-load delivery	750	42.8 - 43.8 (cc/1000st)	170 - 190	

2. Test values

2-1 Timing device	N = rpm mm	750 0.5-1.7	1250 2.9-3.7	1750 4.9-6.1	2100 6.6-7.4
2-2 Supply pump	N = rpm kg/cm ²	600 2.9-3.5	1250 4.5-5.1		2100 6.5-7.1
2-3 Overflow delivery	N = rpm cc/10s	1250 48.0-92.0			

2-4 Fuel injection quantities

Speed control lever pos.	Speed (rpm)	Fuel delivery (cc/1000st)	Charge-air pres (mmHg)	Difference in delivery (cc)
End stop	600	35.2 - 37.2	0	
	750	42.3 - 44.3	170 - 190	
	1250	53.8 - 58.8	510 - 530	
	2100	48.3 - 53.3	510 - 530	
	2650	14.6 - 24.6	510 - 530	
	3050	below 5.0	510 - 530	
Switch off	375	0		
Idle-stop	600	below 3.0	0	
	375	6.0 - 10.0	0	

2-5 Solenoid

Cut-in voltage max. 9 V
Test voltage: 12 - 14 V

3. Dimensions

K	3.2 - 3.4 mm
KF	5.7 - 5.9 mm
MS	1.3 - 1.5 mm
BCS	4.3 - 4.5 mm
Pre-st.	- mm

Control lever angle

α	55 - 63 deg
A	10.5 - 16.0 mm
β	36 - 46 deg
B	10.5 - 15.0 mm
γ	- deg
C	- mm

C10

ZEXEL - Test values
Injection pumps



C11

ZEXEL - Test values
Injection pumps



Note:

- After adjustment of full load fuel injection quantity (600 rpm, 35.2 - 37.2 cc/1000st), set the boost pressure at 180 mmHg (or 0.25 kg/cm²), and at a pump speed of 750 rpm adjust the fuel injection quantity using the BCS spring set screw.
- Check that the injection quantity is within the specified range even when the boost pressure exceeds 700 mmHg.

C12

ZEXEL - Test values

Injection pumps



Test oil
ISO 4113 or
SAE J967d

ZEXEL - TEST VALUES
Distributor pumps
Engine model: 4D56

1/2

BOSCH No.	9 460 610 459
ZEXEL No.	104740-3950
Date:	31.01.1991 [2]
Company:	MITSUBISHI
No.	MD155255

Injection pump no.: 104640-3950 (NP-VE4/10F2100RNP462)

Pump rot.: Clockwise-viewed from drive side Test-nozzle holder combination: Test pressure line:
i 688 901 000 1 680 750 017

1. Setting values	Speed (rpm)	Setting values	Charge-air pressure bar (mmHg)	Difference in delivery (cc)
1-1 Timing device travel	1250	3.5 - 3.9 (mm)	540 - 560	4.5
1-2 Supply pump pressure	1250	4.5 - 5.1 (kg/cm ²)	540 - 560	
1-3 Full load delivery	1250	61.4 - 62.4 (cc/1000st)	540 - 560	
1-3 Full load delivery	750	60.4 - 61.4 (cc/1000st)	320 - 340	2.0
1-4 Idle speed regulation	375	6.5 - 9.5 (cc/1000st)	0	
1-5 Start	100	63.0 - 83.0 (cc/1000st)	0	5.5
1-6 Full-load speed regulation	2650	22.2 - 28.2 (cc/1000st)	540 - 560	
1-7 Load-timer adjustment	1250	T = 0.4-0.8 (mm)	540 - 460	

2. Test values

2-1 Timing device	N = rpm mm	500 0.6-1.8	750 1.4-2.6	1250 3.3-4.1	2100 6.6-7.8
2-2 Supply pump	N = rpm kg/cm ²		600 2.9-3.5	1250 4.5-5.1	2100 6.5-7.1
2-3 Overflow delivery	N = rpm cc/10s			1250 48.0-92.0	

2-4 Fuel injection quantities

Speed control lever pos.	Speed (rpm)	Fuel delivery (cc/1000st)	Charge-air pres (mmHg)	Difference in delivery (cc)
End stop	1250	60.9 - 62.9	540 - 560	
	600	45.8 - 50.8	0	
	750	59.9 - 61.9	320 - 340	
	2100	52.8 - 57.8	540 - 560	
	2650	20.2 - 30.2	540 - 560	
	3050	below 5.0	540 - 560	
Switch off	375	0	0	
Idle-stop	600	below 3.0	0	
	375	6.0 - 10.0	0	

2-5 Solenoid Cut-in voltage max. 8 V
Test voltage: 12 - 14 V

3. Dimensions

K	3.2 - 3.4 mm
KF	5.7 - 5.9 mm
MS	0.9 - 1.1 mm
BCS	3.6 - 3.8 mm
Pre-st.	- mm
Control lever angle	
α	19 - 27° deg
A	10.9 - 16.0 mm
β	38 - 48° deg
B	12.1 - 15.6 mm
γ	- deg
C	- mm

C13

ZEXEL - Test values
Injection pumps



C14

ZEXEL - Test values
Injection pumps



1. Adjustment

1) Fix the control lever in the position satisfying the following conditions:

Boost Pressure: 540 - 560 mmHg
 Pump Speed : 1250 rpm
 Fuel Injection Quantity: 49.8 - 50.8 cc/1000st

2) With the control lever positioned as described in 1) above, adjust the governor sleeve so that the Timer Stroke conforms to the specified values (1 - 7).

2. Confirmation of Timer Characteristics

Fix the control lever in the position satisfying the following conditions, and confirm the Timer Stroke.

Control lever position			Specified values	
Pump speed (rpm)	Fuel injection quantity (cc/1000st)	Boost pressure (mmHg)	Timer stroke (mm)	Timer stroke reduction value (mm)
1250	49.3 - 51.3	540 - 560	(3.1)	0.2 - 1.0
1250	38.7 - 41.7	540 - 560	(2.3)	0.8 - 2.0

- After adjustment of full load fuel injection quantity (1250 rpm, 60.9 - 62.9 cc/1000st), set the boost pressure at 330 mmHg or 0.45 kg/cm², and at a pump speed of 750 rpm adjust the fuel injection quantity using the BCS spring set screw.
- To adjust the timer stroke supply boost pressure of 550 mmHg (0.75 kg/cm²), move the control lever to a position where the full-load injection quantity can be obtained, and then adjust the timer stroke.

Test oil
ISO 4113 or
SAE J967d

ZEXEL - TEST VALUES
Distributor pumps
Engine model: 4D56-T

BOSCH No. 9 460 610 460
ZEXEL No. 104740-3960
Date: 31.01.1991 [2]
Company: MITSUBISHI
No. MD155258

Injection pump no.: 104640-3960 (NP-VE4/10F210ORNP577)

Pump rot.: Clockwise-viewed from drive side Test-nozzle holder combination: 1 688 901 000 Test pressure line: 1 680 750 017

1. Setting values	Speed (rpm)	Setting values	Charge-air pressure bar (mmHg)	Difference in delivery (cc)
1-1 Timing device travel	1250	3.5 - 3.9 (mm)	540 - 560	
1-2 Supply pump pressure	1250	4.5 - 5.1 (kg/cm ²)	540 - 560	
1-3 Full load delivery	1250 (Full)	61.4 - 62.4 (cc/1000st)	540 - 560	4.5
Full load delivery	750 (BCS)	60.4 - 61.4 (cc/1000st)	320 - 340	
1-4 Idle speed regulation	375	6.5 - 9.5 (cc/1000st)	0	2.0
1-5 Start	100	63.0 - 83.0 (cc/1000st)	0	
1-6 Full-load speed regulation	2650	22.2 - 28.2 (cc/1000st)	540 - 560	5.5
1-7 Load-timer adjustment	1250	T = 0.4-0.8 (mm)	540 - 460	

2. Test values

2-1 Timing device	N = rpm mm	500 0.6-1.8	750 1.4-2.6	1250 3.3-4.1	2100 6.6-7.8
2-2 Supply pump	N = rpm kg/cm ²		600 2.9-3.5	1250 4.5-5.1	2100 6.5-7.1
2-3 Overflow delivery	N = rpm cc/10s			1250 48.0-92.0	

2-4 Fuel injection quantities

Speed control lever pos.	Speed (rpm)	Fuel delivery (cc/1000st)	Charge-air pres (mmHg)	Difference in delivery (cc)
End stop	1250 (Full)	60.9 - 62.9	540 - 560	
	600	45.8 - 50.8	0	
	750 (BCS)	59.9 - 61.9	320 - 340	
	2100	52.8 - 57.8	540 - 560	
	2650	20.2 - 30.2	540 - 560	
	3050	below 5.0	540 - 560	
Switch off	375	0	0	
Idle-stop	600	below 3.0	0	
	375	6.0 - 10.0	0	

2-5 Solenoid Cut-in voltage max. 8 V Test voltage: 12 - 14 V

3. Dimensions

K	3.2 - 3.4 mm
KF	5.7 - 5.9 mm
MS	0.9 - 1.1 mm
BCS	3.6 - 3.8 mm
Pre-st.	- mm
Control lever angle	
α	19 - 27° deg
A	10.9 - 16.0 mm
β	36 - 46° deg
B	11.4 - 15.0 mm
γ	- deg
C	- mm

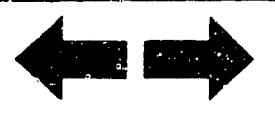

1. Adjustment

1) Fix the control lever in the position satisfying the following conditions:

Boost Pressure: 540 - 560 mmHg
 Pump Speed : 1250 rpm
 Fuel Injection Quantity: 49.8 - 50.8 cc/1000st

2) With the control lever positioned as described in 1) above, adjust the governor sleeve so that the Timer Stroke conforms to the specified values (1 - 7).

2. Confirmation of Timer Characteristics

Fix the control lever in the position satisfying the following conditions, and confirm the Timer Stroke.

Control lever position			Specified values	
Pump speed (rpm)	Fuel injection quantity (cc/1000st)	Boost pressure (mmHg)	Timer stroke (mm)	Timer stroke reduction value (mm)
1250	49.3 - 51.3	540 - 560	(3.1)	0.2 - 1.0
1250	38.7 - 41.7	540 - 560	(2.3)	0.8 - 2.0

Under the following conditions, alter the potentiometer's installation position so that the out-put voltage equals the specified value.

Adjustment Conditions			Specified Value	Remarks
Control lever position	Pump speed (rpm)	Fuel injection quantity (cc/1000st)	Out-put voltage (V)	
Measure	750	35.5 ±1	5.0 ± 0.03	Adjust. point
Idle	-	-	above 1.0	Check point
Full speed	-	-	(8.6)	Check point

(In-put voltage: 10V)

- After adjustment of full load fuel injection quantity (1250 rpm, 60.9-62.9 cc/1000st), set the boost pressure at 330 mmHg or 0.45 kg/cm², and at a pump speed of 750 rpm adjust the fuel injection quantity using the BCS spring set screw.
- To adjust the timer stroke supply boost pressure of 550 mmHg (0.75 kg/cm²), move the control lever to a position where the full-load injection quantity can be obtained, and then adjust the timer stroke.

Test oil
ISO 4113 or
SAE J967d

ZEXEL - TEST VALUES
Distributor pumps
Engine model: 4D56

1/3

BOSCH No.	9 460 610 461
ZEXEL No.	104740-3970
Date:	31.01.1991 [1]
Company:	MITSUBISHI
No.	MD155264

Injection pump no.: 104640-3970

(NP-VE4/10F2100RNP650)

Pump rot.: Clockwise-viewed from drive side

Test-nozzle holder combination:
1 688 901 000

Test pressure line:
1 680 750 017

1. Setting values	Speed (rpm)	Setting values	Charge-air pressure bar (mmHg)	Difference in delivery (cc)
1-1 Timing device travel	1250	3.5 - 3.9 (mm)	540 - 560	
1-2 Supply pump pressure	1250	4.5 - 5.1 (kg/cm ²)	540 - 560	
1-3 Full load delivery	1250 (Full)	61.4 - 62.4 (cc/1000st)	540 - 560	4.5
Full load delivery	750 (BCS)	60.4 - 61.4 (cc/1000st)	320 - 340	
1-4 Idle speed regulation	375	10.5 - 13.5 (cc/1000st)	0	2.0
1-5 Start	100	63.0 - 83.0 (cc/1000st)	0	
1-6 Full-load speed regulation	2650	22.2 - 28.2 (cc/1000st)	540 - 560	5.5
1-7 Load-timer adjustment	1250	T = 0.4-0.8 (mm)	540 - 460	

2. Test values

2-1 Timing device	N = rpm mm	500 0.6-1.8	750 1.4-2.6	1250 3.3-4.1	1750 5.2-6.4	2100 6.6-7.8
2-2 Supply pump	N = rpm kg/cm ²		600 2.9-3.5	1250 4.5-5.1		2100 6.5-7.1
2-3 Overflow delivery	N = rpm cc/10s			1250 48.0-92.0		

2-4 Fuel injection quantities

Speed control lever pos.	Speed (rpm)	Fuel delivery (cc/1000st)	Charge-air pres (mmHg)	Difference in delivery (cc)
End stop	1250 (Full)	60.9 - 62.9	540 - 560	
	600	45.8 - 50.8	0	
	750 (BCS)	59.9 - 61.9	320 - 340	
	2100	52.8 - 57.8	540 - 560	
	2650	21.7 - 28.7	540 - 560	
Switch off	3050	below 5.0	540 - 560	
	375	0	0	
Idle-stop	750	below 3.0	0	
	375	10.0 - 14.0	0	

2-5 Solenoid

Cut-in voltage max. 8 V
Test voltage: 12 - 14 V

3. Dimensions

K	3.2 - 3.4 mm
KF	5.7 - 5.9 mm
MS	0.9 - 1.1 mm
BCS	3.6 - 3.8 mm
Fullst.	7.4 - 8.2 mm

Control lever angle

α	19 - 27° deg
A	10.9 - 16.0 mm
β	34 - 44° deg
B	10.7 - 14.3 mm
γ	- deg
C	- mm

C23

ZEXEL - Test values
Injection pumps



C24

ZEXEL - Test values
Injection pumps



1. Adjustment

1) Fix the control lever in the position satisfying the following conditions:

Boost Pressure: 540 - 560 mmHg
 Pump Speed : 1250 rpm
 Fuel Injection Quantity: 49.8 - 50.8 cc/1000st

2) With the control lever positioned as described in 1) above, adjust the governor sleeve so that the Timer Stroke conforms to the specified values (1 - 7).

2. Confirmation of Timer Characteristics

Fix the control lever in the position satisfying the following conditions, and confirm the Timer Stroke.

Control lever position			Specified values	
Pump speed (rpm)	Fuel injection quantity (cc/1000st)	Boost pressure (mmHg)	Timer stroke (mm)	Timer stroke reduction value (mm)
1250	49.3 - 51.3	540 - 560	(3.1)	0.2 - 1.0
1250	38.7 - 41.7	540 - 560	(2.3)	0.8 - 2.0

Under the following conditions, alter the potentiometer's installation position so that the out-put voltage equals the specified value.

Adjustment Conditions			Specified Value	Remarks
Control lever position	Pump speed (rpm)	Fuel injection quantity (cc/1000st)	Out-put voltage (V)	
Measure	750	22.3 ± 1	4.0 ± 0.03	Adjust. point
Idle	-	-	above 1.0	Check point
Full speed	-	-	(8.6)	Check point

(In-put voltage: 10V)

1. After adjusting of full load fuel injection quantity of 1250 rpm, reduce the speed to 750 rpm and the boost pressure to 330 mmHg (0.45 kg/cm²). Next, set the appropriate fuel injection quantity by turning the BCS spring's set screw.
2. Adjust the timing device stroke to a boost pressure of 550 mmHg or (0.75 kg/cm²), and move the control lever to the full-load injection quantity position.

A/T LINK LEVER ADJUSTMENT

1. Move the control lever from the idling position to the full speed position and confirm that the A/T lever stroke (L) is 32.9 ± 1 mm.
2. If dimension L is not as specified, loosen the bolt and adjust by altering the A/T lever position.

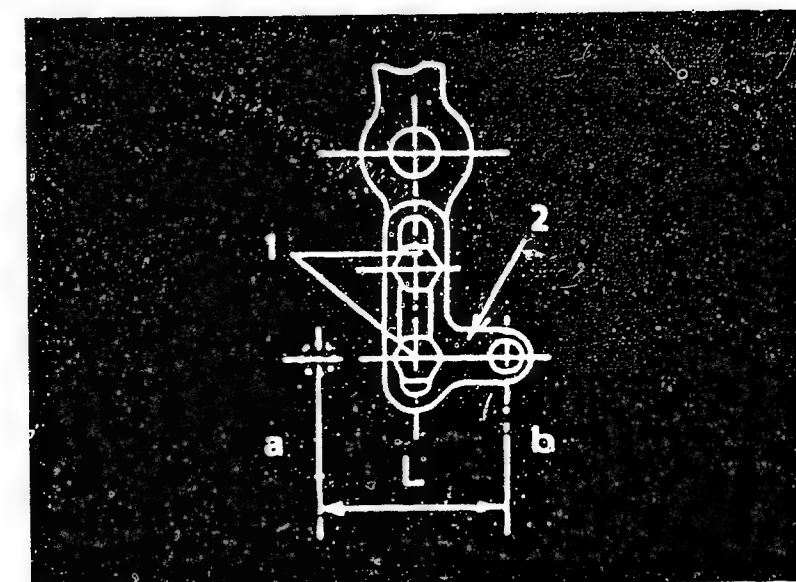

Figure 14

1 = Bolt
2 = A/T Lever

a = Full-speed
b = Idling



Test oil
ISO 4113 or
SAE J967d

ZEXEL - TEST VALUES
Distributor pumps
Engine model: 4D56

1/2

BOSCH No. 9 460 610 462
ZEXEL No. 104740-8040
Date: 31.01.1991 [2]
Company: MITSUBISHI
No. MD155250

Injection pump no.: 104640-8040 (NP-VE4/10F2100RNP430)

Pump rot.: Clockwise-viewed from drive side Test-nozzle holder combination: 1 688 901 000 Test pressure line: 1 680 750 017

1. Setting values	Speed (rpm)	Setting values	Charge-air pressure bar (mmHg)	Difference in delivery (cc)
1-1 Timing device travel	1250	3.5 - 3.9 (mm)	540 - 560	
1-2 Supply pump pressure	1250	4.5 - 5.1 (kg/cm ²)	540 - 560	
1-3 Full load delivery	1250	61.4 - 62.4 (cc/1000st)	540 - 560	4.5
Full load delivery	750	60.4 - 61.4 (cc/1000st)	320 - 340	
1-4 Idle speed regulation	375	6.5 - 9.5 (cc/1000st)	0	2.0
1-5 Start	100	63.0 - 83.0 (cc/1000st)	0	
1-6 Full-load speed regulation	2650	22.2 - 28.2 (cc/1000st)	540 - 560	5.5
1-7 Load-timer adjustment	1250	T = 0.4-0.8 (mm)	540 - 560	

2. Test values

2-1 Timing device	N = rpm mm	500 0.6-1.8	750 1.4-2.6	1250 3.3-4.1	2100 6.6-7.8
2-2 Supply pump	N = rpm kg/cm ²		600 2.9-3.5	1250 4.5-5.1	2100 6.5-7.1
2-3 Overflow delivery	N = rpm cc/10s			1250 48.0-92.0	
2-4 Fuel injection quantities					
Speed control lever pos.	Speed (rpm)	Fuel delivery (cc/1000st)	Charge-air pres (mmHg)	Difference in delivery (cc)	
End stop	1250	60.9 - 62.9	540 - 560		
	600	45.8 - 50.8	0		
	750	59.9 - 61.9	320 - 340		
	2100	52.8 - 57.8	540 - 560		
	2650	20.2 - 30.2	540 - 560		
	3050	below 5.0	540 - 560		
Switch off	375	0	0		
Idle-stop	600	below 3.0	0		
	375	6.0 - 10.0	0		
2-5 Solenoid	Cut-in voltage max. 8 V Test voltage: 12 - 14 V				

3. Dimensions

K	3.2 - 3.4 mm
KF	5.7 - 5.9 mm
MS	0.9 - 1.1 mm
BCS	3.6 - 3.8 mm
Pre-st.	- mm
Control lever angle	
α	55 - 63° deg
A	10.9 - 16.0 mm
β	38 - 48° deg
B	12.1 - 15.6 mm
γ	- deg
C	- mm

D1

ZEXEL - Test values
Injection pumps



D2

ZEXEL - Test values
Injection pumps



1. Adjustment

1) Fix the control lever in the position satisfying the following conditions:

Boost Pressure: 540 - 560 mmHg
 Pump Speed : 1250 rpm
 Fuel Injection Quantity: 49.8 - 50.8 cc/1000st

2) With the control lever positioned as described in 1) above, adjust the governor sleeve so that the Timer Stroke conforms to the specified values (1 - 7).

2. Confirmation of Timer Characteristics

Fix the control lever in the position satisfying the following conditions, and confirm the Timer Stroke.

Control lever position			Specified values	
Pump speed (rpm)	Fuel injection quantity (cc/1000st)	Boost pressure (mmHg)	Timer stroke (mm)	Timer stroke reduction value (mm)
1250	49.3 - 51.3	540 - 560	(3.1)	0.2 - 1.0
1250	38.7 - 41.7	540 - 560	(2.3)	0.8 - 2.0

1. After adjustment of full load fuel injection quantity of 1250 rpm, set the boost pressure at 330 mmHg or 0.45 kg/cm², and at a pump speed of 750 rpm adjust the fuel injection quantity using the BCS spring set screw.
2. To adjust the timer stroke supply boost pressure of 550 mmHg (0.75 kg/cm²), move the control lever to a position where the full-load injection quantity can be obtained.

Test oil
ISO 4113 or
SAE J967d

ZEXEL - TEST VALUES
Distributor pumps
Engine model: 4D56

1/2

BOSCH No. 9 460 610 463
ZEXEL No. 104740-8050
Date: 31.01.1991 [2]
Company: MITSUBISHI
No. MD155251

Injection pump no.: 104640-8050 (NP-VE4/10F2100RNP430)

Pump rot.: Clockwise-viewed from drive side Test-nozzle holder combination: 1 688 901 000 Test pressure line: 1 680 750 017

1. Setting values	Speed (rpm)	Setting values	Charge-air pressure bar (mmHg)	Difference in delivery (cc)
1-1 Timing device travel	1250	3.5 - 3.9 (mm)	540 - 560	
1-2 Supply pump pressure	1250	4.5 - 5.1 (kg/cm ²)	540 - 560	
1-3 Full load delivery	1250	61.4 - 62.4 (cc/1000st)	540 - 560	4.5
Full load delivery	750	60.4 - 61.4 (cc/1000st)	320 - 340	
1-4 Idle speed regulation	375	6.5 - 9.5 (cc/1000st)	0	2.0
1-5 Start	100	63.0 - 83.0 (cc/1000st)	0	
1-6 Full-load speed regulation	2650	22.2 - 28.2 (cc/1000st)	540 - 560	5.5
1-7 Load-timer adjustment	1250	T = 0.4-0.8 (mm)	540 - 560	

2. Test values

2-1 Timing device	N = rpm mm	500 0.6-1.8	750 1.4-2.6	1250 3.3-4.1	2100 6.6-7.8
2-2 Supply pump	N = rpm kg/cm ²		600 2.9-3.5	1250 4.5-5.1	2100 6.5-7.1
2-3 Overflow delivery	N = rpm cc/10s			1250 48.0-92.0	

2-4 Fuel injection quantities

Speed control lever pos.	Speed (rpm)	Fuel delivery (cc/1000st)	Charge-air pres (mmHg)	Difference in delivery (cc)
End stop	1250	60.9 - 62.9	540 - 560	
	600	45.8 - 50.8	0	
	750	59.9 - 61.9	320 - 340	
	2100	52.8 - 57.8	540 - 560	
	2650	20.2 - 30.2	540 - 560	
	3050	below 5.0	540 - 560	
Switch off	375	0	0	
Idle-stop	600	below 3.0	0	
	375	6.0 - 10.0	0	

2-5 Solenoid Cut-in voltage max. 8 V Test voltage: 12 - 14 V

3. Dimensions

K. 3.2 - 3.4 mm
KF 5.7 - 5.9 mm
MS 0.9 - 1.1 mm
BCS 3.6 - 3.8 mm
Pre-st. - mm

Control lever angle

α 55 - 63° deg
A 10.9 - 16.0 mm
β 38 - 48° deg
B 12.1 - 15.6 mm
γ - deg
C - mm

D5

ZEXEL - Test values
Injection pumps



D6

ZEXEL - Test values
Injection pumps



1. Adjustment

1) Fix the control lever in the position satisfying the following conditions:

Boost Pressure: 540 - 560 mmHg
 Pump Speed : 1250 rpm
 Fuel Injection Quantity: 49.8 - 50.8 cc/1000st

2) With the control lever positioned as described in 1) above, adjust the governor sleeve so that the Timer Stroke conforms to the specified values (1 - 7).

2. Confirmation of Timer Characteristics

Fix the control lever in the position satisfying the following conditions, and confirm the Timer Stroke.

Control lever position			Specified values	
Pump speed (rpm)	Fuel injection quantity (cc/1000st)	Boost pressure (mmHg)	Timer stroke (mm)	Timer stroke reduction value (mm)
1250	49.3 - 51.3	540 - 560	(3.1)	0.2 - 1.0
1250	38.7 - 41.7	540 - 560	(2.3)	0.8 - 2.0

1. After adjustment of full load fuel injection quantity of 1250 rpm, set the boost pressure at 330 mmHg or 0.45 kg/cm², and at a pump speed of 750 rpm adjust the fuel injection quantity using the BCS spring set screw.
2. To adjust the timer device boost pressure of 550 mmHg (0.75 kg/cm²), move the control lever to a position where the full-load injection quantity can be obtained.

D7

ZEXEL - Test values
 Injection pumps



D8

ZEXEL - Test values
 Injection pumps



Test oil
ISO 4113 or
SAE J967d

ZEXEL - TEST VALUES
Distributor pumps
Engine model: 4D56

1/2

BOSCH No.	9 460 610 442
ZEXEL No.	104740-8060
Date:	31.01.1991 [1]
Company:	MITSUBISHI
No.	MD155261

Injection pump no.: 104640-8060

(NP-VE4/10F2100RNP802)

Pump rot.: Clockwise-viewed from drive side

Test-nozzle holder combination:
1 688 901 000

Test pressure line:
1 680 750 017

1. Setting values		Speed (rpm)	Setting values	Charge-air pressure bar (mmHg)	Difference in delivery (cc)
1-1	Timing device travel	1250	3.5 - 3.9 (mm)	540 - 560	
1-2	Supply pump pressure	1250	4.5 - 5.1 (kg/cm ²)	540 - 560	
1-3	Full load delivery	1250 (Full)	66.4 - 67.4 (cc/1000st)	540 - 560	4.5
	Full load delivery	750 (BCS)	61.9 - 62.9 (cc/1000st)	320 - 340	
1-4	Idle speed regulation	375	8.5 - 11.5 (cc/1000st)	0	2.0
1-5	Start	100	63.0 - 83.0 (cc/1000st)	0	
1-6	Full-load speed regulation	2650	22.2 - 28.2 (cc/1000st)	540 - 560	5.5
1-7	Load-timer adjustment	1250	T = 0.4-0.8 (mm)	540 - 560	

2. Test values

2-1 Timing device	N = rpm mm	500 0.6-1.8	750 1.4-2.6	1250 3.3-4.1	1750 5.2-6.4	2150 6.6-7.8
2-2 Supply pump	N = rpm kg/cm ²		600 2.9-3.5	1250 4.5-5.1		2100 6.5-7.1
2-3 Overflow delivery	N = rpm cc/10s			1250 48.0-92.0		

2-4 Fuel injection quantities

Speed control lever pos.	Speed (rpm)	Fuel delivery (cc/1000st)	Charge-air pres (mmHg)	Difference in delivery (cc)
End stop	1250 (Full)	65.9 - 67.9	540 - 560	
	600	42.8 - 47.8	0	
	750 (BCS)	61.4 - 63.4	320 - 340	
	2100	59.9 - 64.9	540 - 560	
	2650	21.7 - 28.7	540 - 560	
Switch off	3050	below 5.0	540 - 560	
	375	0	0	
Idle-stop	750	below 3.0	0	
	375	8.0 - 12.0	0	

2-5 Solenoid
Cut-in voltage max. 8 V
Test voltage: 12 - 14 V

3. Dimensions

K	3.2 - 3.4 mm
KF	5.7 - 5.9 mm
MS	0.6 - 0.8 mm
BCS	6.0 - 6.2 mm
Fullst.	7.4 - 8.2 mm

Control lever angle

α	55 - 63° deg
A	10.9 - 16.0 mm
β	36 - 46° deg
B	11.4 - 15.0 mm
γ	- deg
C	- mm

D9

ZEXEL - Test values
Injection pumps



D10

ZEXEL - Test values
Injection pumps



1. Adjustment

1) Fix the control lever in the position satisfying the following conditions:

Boost Pressure: 540 - 560 mmHg
 Pump Speed : 1250 rpm
 Fuel Injection Quantity: 52.8 - 53.8 cc/1000st

2) With the control lever positioned as described in 1) above, adjust the governor sleeve so that the Timer Stroke conforms to the specified values (1 - 7).

2. Confirmation of Timer Characteristics

Fix the control lever in the position satisfying the following conditions, and confirm the Timer Stroke.

Control lever position			Specified values	
Pump speed (rpm)	Fuel injection quantity (cc/1000st)	Boost pressure (mmHg)	Timer stroke (mm)	Timer stroke reduction value (mm)
1250	52.3 - 54.3	540 - 560	(3.1)	0.2 - 1.0
1250	38.7 - 41.7	540 - 560	(2.3)	0.8 - 2.0

1. After adjustment of full load fuel injection quantity of 1250 rpm, set the boost pressure at 330 mmHg or 0.45 kg/cm², and at a pump speed of 750 rpm adjust the fuel injection quantity using the BCS spring set screw.
2. To adjust the timer stroke boost pressure of 550 mmHg or (0.75 kg/cm²), move the control lever to a position where the full-load injection quantity can be obtained.

C13

ZEXEL - Test values

Injection pumps



C14

ZEXEL - Test values

Injection pumps



Test oil
ISO 4113 or
SAE J967d

ZEXEL - TEST VALUES
Distributor pumps
Engine model: 4D56

1/3

BOSCH No.	9 460 610 464
ZEXEL No.	104740-8070
Date:	31.01.1991 [1]
Company:	MITSUBISHI
No.	MD155259

Injection pump no.: 104640-8070

(NP-VE4/10F2100RNP688)

Pump rot.: Clockwise-viewed from drive side

Test-nozzle holder combination:
1 688 901 000Test pressure line:
1 680 750 017

1. Setting values		Speed (rpm)	Setting values	Charge-air pressure bar (mmHg)	Difference in delivery (cc)
1-1	Timing device travel	1250	3.5 - 3.9 (mm)	540 - 560	
1-2	Supply pump pressure	1250	4.5 - 5.1 (kg/cm ²)	540 - 560	
1-3	Full load delivery	1250 (Full)	66.4 - 67.4 (cc/1000st)	540 - 560	4.5
	Full load delivery	750 (BCS)	61.9 - 62.9 (cc/1000st)	320 - 340	
1-4	Idle speed regulation	375	8.5 - 11.5 (cc/1000st)	0	2.0
1-5	Start	100	63.0 - 83.0 (cc/1000st)	0	
1-6	Full-load speed regulation	2650	22.2 - 28.2 (cc/1000st)	540 - 560	5.5
1-7	Load-timer adjustment	1250	T = 0.4-0.8 (mm)	540 - 560	

2. Test values

2-1 Timing device	N = rpm	500	750	1250	1750	2100
	mm	0.6-1.8	1.4-2.6	3.3-4.1	5.2-6.4	6.6-7.8
2-2 Supply pump	N = rpm		600	1250		2100
	kg/cm ²		2.9-3.5	4.5-5.1		6.5-7.1
2-3 Overflow delivery	N = rpm			1250		
	cc/10s			48.0-92.0		

2-4 Fuel injection quantities

Speed control lever pos.	Speed (rpm)	Fuel delivery (cc/1000st)	Charge-air pres (mmHg)	Difference in delivery (cc)
End stop	1250 (Full)	65.9 - 67.9	540 - 560	
	600	42.8 - 47.8	0	
	750 (BCS)	61.4 - 63.4	320 - 340	
	2100	59.9 - 64.9	540 - 560	
	2650	21.7 - 28.7	540 - 560	
Switch off	3050	below 5.0	540 - 560	
	375	0	0	
Idle-stop	750	below 3.0	0	
	375	8.0 - 12.0	0	

2-5

Solenoid

Cut-in voltage max. 8 V
Test voltage: 12 - 14 V

3. Dimensions

K	3.2 - 3.4 mm
KF	5.7 - 5.9 mm
MS	0.6 - 0.8 mm
BCS	6.0 - 6.2 mm
Fullst.	7.4 - 8.2 mm

Control lever angle

α	55 - 63° deg
A	10.9 - 16.0 mm
β	36 - 46° deg
B	11.4 - 15.0 mm
γ	- deg
C	- mm

D13

ZEXEL - Test values

Injection pumps



D14

ZEXEL - Test values

Injection pumps



1. Adjustment

1) Fix the control lever in the position satisfying the following conditions:

Boost Pressure: 540 - 560 mmHg
 Pump Speed : 1250 rpm
 Fuel Injection Quantity: 52.8 - 53.8 cc/1000st

2) With the control lever positioned as described in 1) above, adjust the governor sleeve so that the Timer Stroke conforms to the specified values (1 - 7).

2. Confirmation of Timer Characteristics

Fix the control lever in the position satisfying the following conditions, and confirm the Timer Stroke.

Control lever position			Specified values	
Pump speed (rpm)	Fuel injection quantity (cc/1000st)	Boost pressure (mmHg)	Timer stroke (mm)	Timer stroke reduction value (mm)
1250	52.3 - 54.3	540 - 560	(3.1)	0.2 - 1.0
1250	38.7 - 41.7	540 - 560	(2.3)	0.8 - 2.0

Under the following conditions, alter the potentiometer's installation position so that the out-put voltage equals the specified value.

Adjustment Conditions			Specified Value	Remarks
Control lever position	Pump speed (rpm)	Fuel injection quantity (cc/1000st)	Out-put voltage (V)	
Measure	750	35.5 ±1	5.0 ± 0.03	Adjust. point
Idle	-	-	above 1.0	Check point
Full speed	-	-	(8.8)	Check point

(In-put voltage: 10V)

- After adjusting full load fuel injection quantity of 1250 rpm, (65.9-67.9 cc/1000st), set the boost pressure at 330 mmHg (or 0.45 kg/cm²), and at a pump speed of 750 rpm adjust the fuel injection quantity using the BCS spring set screw.
- Adjust the timing device stroke at a boost pressure of 550 mmHg or 0.75 kg/cm² by moving the control lever to the full-load injection quantity position.

D17

ZEXEL - Test values
Injection pumps



D18

ZEXEL - Test values
Injection pumps



Test oil
ISO 4113 or
SAE J967d

ZEXEL - TEST VALUES
Distributor pumps
Engine model: 4D56-T

1/3

BOSCH No. 9 460 610 465
ZEXEL No. 104740-8080
Date: 31.01.1991 [1]
Company: MITSUBISHI
No. MD155262

Injection pump no.: 104640-8080

(NP-VE4/10F2100RNP801)

Pump rot.: Clockwise-viewed from drive side

Test-nozzle holder combination:
1 688 901 000

Test pressure line:
1 680 750 017

1. Setting values	Speed (rpm)	Setting values	Charge-air pressure bar (mmHg)	Difference in delivery (cc)
1-1 Timing device travel	1250	3.5 - 3.9 (mm)	540 - 560	
1-2 Supply pump pressure	1250	4.5 - 5.1 (kg/cm ²)	540 - 560	
1-3 Full load delivery	1250 (Full)	66.4 - 67.4 (cc/1000st)	540 - 560	4.5
Full load delivery	750 (BCS)	61.9 - 62.9 (cc/1000st)	320 - 340	
1-4 Idle speed regulation	375	10.5 - 13.5 (cc/1000st)	0	2.0
1-5 Start	100	63.0 - 83.0 (cc/1000st)	0	
1-6 Full-load speed regulation	2650	22.2 - 28.2 (cc/1000st)	540 - 560	5.5
1-7 Load-timer adjustment	1250	T = 0.4-0.8 (mm)	540 - 560	

2. Test values

2-1 Timing device	N = rpm mm	500 0.6-1.8	750 1.4-2.6	1250 3.3-4.1	1750 5.2-6.4	2100 6.6-7.8
2-2 Supply pump	N = rpm kg/cm ²		600 2.9-3.5	1250 4.5-5.1		2100 6.5-7.1
2-3 Overflow delivery	N = rpm cc/10s			1250 48.0-92.0		

2-4 Fuel injection quantities

Speed control lever pos.	Speed (rpm)	Fuel delivery (cc/1000st)	Charge-air pres (mmHg)	Difference in delivery (cc)
End stop	1250 (Full)	65.9 - 67.9	540 - 560	
	600	42.8 - 47.8	0	
	750 (BCS)	61.4 - 63.4	320 - 340	
	2100	59.9 - 64.9	540 - 560	
	2650	21.7 - 28.7	540 - 560	
	3050	below 5.0	540 - 560	
Switch off	375	0	0	
Idle-stop	750	below 3.0	0	
	375	10.0 - 14.0	0	

2-5

Solenoid

Cut-in voltage max. 8 V
Test voltage: 12 - 14 V

3. Dimensions

K 3.2 - 3.4 mm
KF 5.7 - 5.9 mm
MS 0.6 - 0.8 mm
BCS 6.0 - 6.2 mm
Fullst. 7.4 - 8.2 mm

Control lever angle

α 55 - 63° deg
A 10.9 - 16.0 mm
 β 34 - 44° deg
B 10.7 - 14.3 mm
 γ - deg
C - mm

D19

ZEXEL - Test values
Injection pumps



D20

ZEXEL - Test values
Injection pumps



1. Adjustment

1) Fix the control lever in the position satisfying the following conditions:

Boost Pressure: 540 - 560 mmHg
 Pump Speed : 1250 rpm
 Fuel Injection Quantity: 52.8 - 53.8 cc/1000st

2) With the control lever positioned as described in 1) above, adjust the governor sleeve so that the Timer Stroke conforms to the specified values (1 - 7).

2. Confirmation of Timer Characteristics

Fix the control lever in the position satisfying the following conditions, and confirm the Timer Stroke.

Control lever position			Specified values	
Pump speed (rpm)	Fuel injection quantity (cc/1000st)	Boost pressure (mmHg)	Timer stroke (mm)	Timer stroke reduction value (mm)
1250	52.3 - 54.3	540 - 560	(3.1)	0.2 - 1.0
1250	38.7 - 41.7	540 - 560	(2.3)	0.8 - 2.0

A/T LINK LEVER ADJUSTMENT

104740-8080 3/3

1. Move the control lever from the idling position to the full speed position and confirm that the A/T lever stroke (L) is $39,2 \pm 1$ mm.
2. If dimension L is not as specified, loosen the bolt and adjust by altering the A/T lever position.
3. After adjustment of full load fuel injection quantity (1250 rpm, 65.9 - 67.9 cc/1000st), set the boost pressure at 330 mmHg or 0.45 kg/cm², and at a pump speed of 750 rpm adjust the fuel injection quantity using the BCS spring set screw.
4. To adjust the timer stroke boost pressure of 550 mmHg (0.75 kg/cm²), move the control lever to a position where the full-load injection quantity can be obtained, and then adjust the timer stroke.

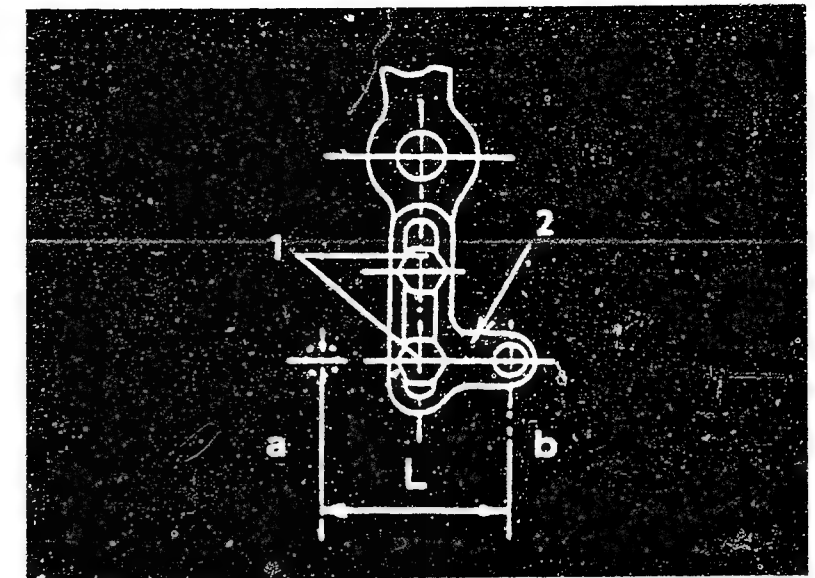

Figure 15

1 = Bolt
2 = A/T Lever

a = Full-speed
b = Idling

D23

ZEXEL - Test values
Injection pumps



D24

ZEXEL - Test values
Injection pumps



Test oil
ISO 4113 or
SAE J967d

ZEXEL - TEST VALUES
Distributor pumps
Engine model: 4D56

1/3

BOSCH No.	9 460 610 466
ZEXEL No.	104740-8090
Date:	31.01.1991 [1]
Company:	MITSUBISHI
No.	MD155260

Injection pump no.: 104640-8090

(NP-VE4/10F2100RNP649)

Pump rot.: Clockwise-viewed from drive side

Test-nozzle holder combination:
1 688 901 000

Test pressure line:
1 680 750 017

1. Setting values	Speed (rpm)	Setting values	Charge-air pressure bar (mmHg)	Difference in delivery (cc)
1-1 Timing device travel	1250	3.5 - 3.9 (mm)	540 - 560	
1-2 Supply pump pressure	1250	4.5 - 5.1 (kg/cm ²)	540 - 560	
1-3 Full load delivery	1250 (Full)	66.4 - 67.4 (cc/1000st)	540 - 560	4.5
Full load delivery	750 (BCS)	61.9 - 62.9 (cc/1000st)	320 - 340	
1-4 Idle speed regulation	375	10.5 - 13.5 (cc/1000st)	0	2.0
1-5 Start	100	63.0 - 83.0 (cc/1000st)	0	
1-6 Full-load speed regulation	2650	22.2 - 28.2 (cc/1000st)	540 - 560	5.5
1-7 Load-timer adjustment	1250	T = 0.4-0.8 (mm)	540 - 560	

2. Test values

2-1 Timing device	N = rpm mm	500 0.6-1.8	750 1.4-2.6	1250 3.3-4.1	1750 5.2-6.4	2100 6.6-7.8
2-2 Supply pump	N = rpm kg/cm ²		600 2.9-3.5	1250 4.5-5.1		2100 6.5-7.1
2-3 Overflow delivery	N = rpm cc/10s			1250 48.0-92.0		

2-4 Fuel injection quantities

Speed control lever pos.	Speed (rpm)	Fuel delivery (cc/1000st)	Charge-air pres (mmHg)	Difference in delivery (cc)
End stop	1250 (Full)	65.9 - 67.9	540 - 560	
	600	42.8 - 47.8	0	
	750 (BCS)	61.4 - 63.4	320 - 340	
	2100	59.9 - 64.9	540 - 560	
	2650	21.7 - 28.7	540 - 560	
Switch off	3050	below 5.0	540 - 560	
	375	0	0	
Idle-stop	750	below 3.0	0	
	375	10.0 - 14.0	0	

2-5 Solenoid
Cut-in voltage max. 8 V
Test voltage: 12 - 14 V

3. Dimensions

K	3.2 - 3.4 mm
KF	5.7 - 5.9 mm
MS	0.6 - 0.8 mm
BCS	6.0 - 6.2 mm
Fullst.	7.4 - 8.2 mm

Control lever angle

α	55 - 63° deg
A	10.9 - 16.0 mm
β	34 - 44° deg
B	10.7 - 14.3 mm
γ	- deg
C	- mm

E1

ZEXEL - Test values
Injection pumps



E2

ZEXEL - Test values
Injection pumps



1. Adjustment

1) Fix the control lever in the position satisfying the following conditions:

Boost Pressure: 540 - 560 mmHg
 Pump Speed : 1250 rpm
 Fuel Injection Quantity: 52.8 - 53.8 cc/1000st

2) With the control lever positioned as described in 1) above, adjust the governor sleeve so that the Timer Stroke conforms to the specified values (1 - 7).

2. Confirmation of Timer Characteristics

Fix the control lever in the position satisfying the following conditions, and confirm the Timer Stroke.

Control lever position			Specified values	
Pump speed (rpm)	Fuel injection quantity (cc/1000st)	Boost pressure (mmHg)	Timer stroke (mm)	Timer stroke reduction value (mm)
1250	52.3 - 54.3	540 - 560	(3.1)	0.2 - 1.0
1250	38.7 - 41.7	540 - 560	(2.3)	0.8 - 2.0

Under the following conditions, alter the potentiometer's installation position so that the out-put voltage equals the specified value.

Adjustment Conditions			Specified Value	Remarks
Control lever position	Pump speed (rpm)	Fuel injection quantity (cc/1000st)	Out-put voltage (V)	
Measure	750	35.5 ± 1	5.0 ± 0.03	Adjust. point
Idle	-	-	above 1.0	Check point
Full speed	-	-	(8.8)	Check point

(In-put voltage: 10V)

1. After adjusting of full load fuel injection quantity of 1250 rpm, (65.9 - 67.9), reduce the speed to 750 rpm and the boost pressure to 330 mmHg (0.45 kg/cm²). Next, set the appropriate fuel injection quantity by turning the BCS spring's set screw.
2. Adjust the timing device stroke to a boost pressure of 550 mmHg or (0.75 kg/cm²), and move the control lever to the full-load injection quantity position.

A/T LINK LEVER ADJUSTMENT

1. Move the control lever from the idling position to the full speed position and confirm that the A/T lever stroke (L) is 32.9 ± 1 mm.
2. If dimension L is not as specified, loosen the bolt and adjust by altering the A/T lever position.

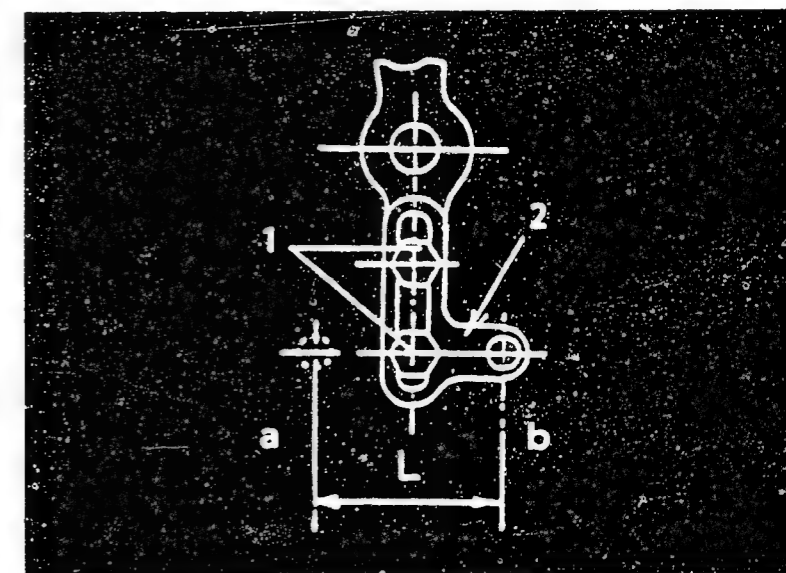

Figure 16

1 = Bolt
2 = A/T Lever

a = Full-speed
b = Idling



Test oil:
ISO 4113 or
SAE J967d

ZEXEL-TEST VALUES
Distributor pumps
Engine model: 4JB1CDT

BOSCH No. 9 460 610 456
ZEXEL No. 104741-5250
Date: 31.01.1991 [0]
Company: ISUZU
No. 89702 83280

Injection pump no.: 104641-5250 (NP-VE4/11F1900RNP578)

Pump rot.: clockwise-viewed from drive side Test-nozzle holder combination: 1 688 901 000 Test pressure line: 1 680 750 017

1. Setting values		Speed (rpm)	Setting values	Charge-air pressure bar (mmHg)	Difference in delivery (cc)
1-1	Time device travel	1700	5.0 - 5.4 (mm)	590 - 610	
1-2	Supply pump pressure	1700	5.2 - 5.6 (kg/cm ²)	590 - 610	
1-3	Full load delivery	1250 (Full)	60.0 - 61.0 (cc/1000st)	590 - 610	3.5
	Full load delivery	900 (BCS)	48.3 - 49.3 (cc/1000st)	340 - 360	4.5
1-4	Idle speed regulation	385	3.1 - 7.1 (cc/1000st)	0	2.0
1-5	Start	100	60.0 - 100.0 (cc/1000st)	0	
1-6	Full-load speed regulation	2300	19.3 - 25.3 (cc/1000st)	590 - 610	4.5

2. Test values

2-1 Timing device	Solenoid timer N = rpm mm	ON		OFF	
		550	1450	1700	1850
		above 0.5	1.9 - 3.1	4.9 - 5.5	5.8 - 6.6
2-2 Supply pump	N = rpm kg/cm ²			1700	1850
				5.2 - 5.6	5.6 - 6.2
2-3 Overflow delivery	N = rpm cc/10s	1700	1700		
		60.0 - 120.0	93 - 203		

2-4 Fuel delivery quantities

Speed control lever pos.	Speed (rpm)	Fuel delivery (cc/1000st)	Charge-air pres (mmHg)	Difference in delivery (cc)
End stop	1250 (Full)	59.5 - 61.5	590 - 610	
	900 (BCS)	47.8 - 49.8	340 - 360	
	600	30.3 - 40.3	90 - 110	
	750	36.7 - 42.7	170 - 190	
	1250	33.3 - 41.3	0	
	1800	50.7 - 59.7	590 - 610	
	2300	18.8 - 25.8	590 - 610	
	2400	below 15.0	590 - 610	
	2500	below 5.0	590 - 610	
Switch off	385	0	0	
Idle-stop	500	below 3.0	0	
	385	3.1 - 7.1	0	

2-5 Solenoid Cut-in voltage max.: 8 V Test voltage: 12 - 14 V

3. Dimensions

K	2.7 - 2.9 mm
KF	5.4 - 5.6 mm
MS	0.8 - 1.0 mm
BCS	4.4 - 4.6 mm
Prest.	0.43 - 0.47 mm
Control lever angle	
α	14 - 22° deg
A	11.3 - 14.7 mm
β	32 - 42° deg
B	10.2 - 13.6 mm
γ	- deg
C	- mm



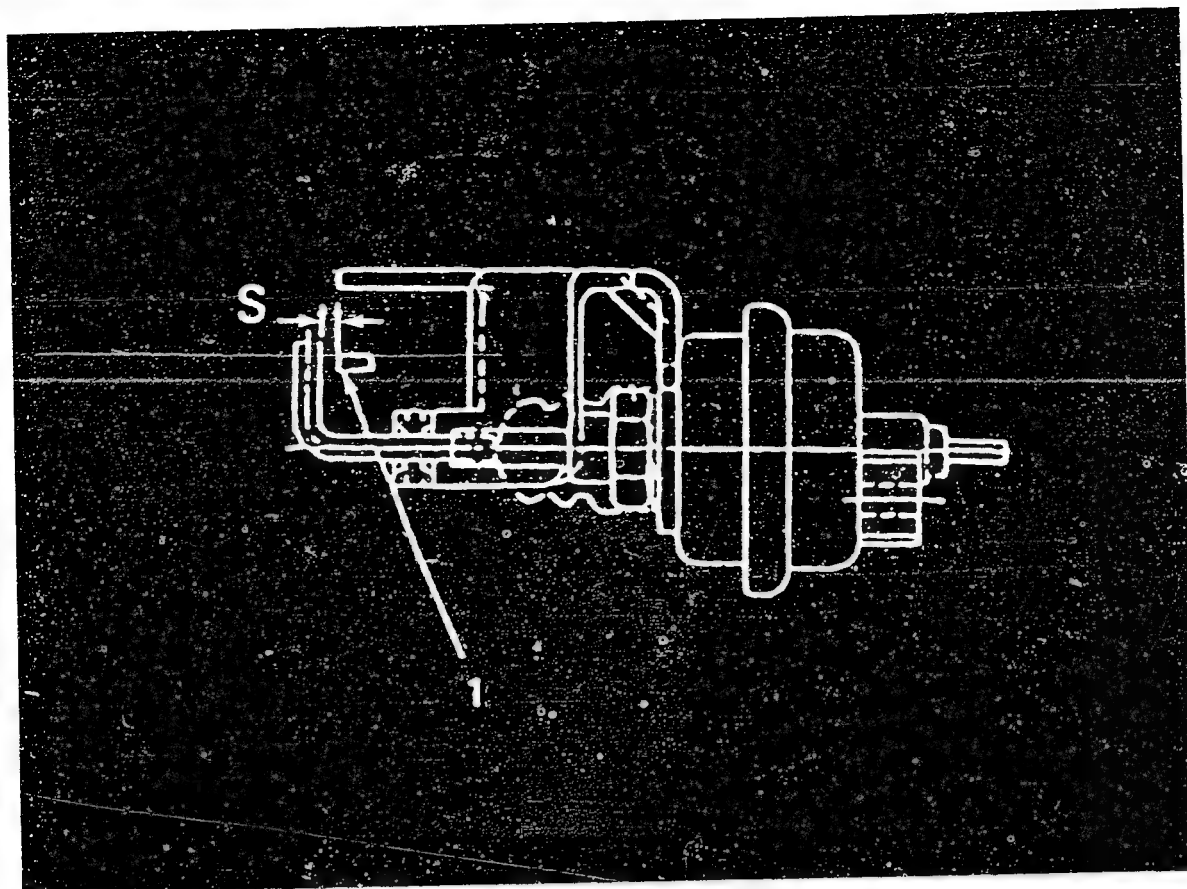

Figure 17

104741-5250 2/3

1 = Control lever
(Idling position)

■ V-FICD ADJUSTMENT

1. Adjust the bracket so that the clearance S is 1^{+1} mm.
2. Apply 400 mmHg negative pressure to the inside of the actuator and confirm that the actuator shaft moves the full stroke.



Injection quantity specifications Boost pressure=600mmHg(0.81 kg/cm ²)	
I/P speed (rpm)	Injection quantity (mm ³ /1000st)
1000	26.9 - 28.9

1. Fix the dummy bolt in a position where pump speed is 1000 rpm and injection quantity is 26.9 - 28.9.
2. Move the microswitch in the direction of the arrow from the ON to the OFF position and fix it in this position.
3. Remove the dummy bolt's fixing bracket and confirm that the microswitch is OFF when it contacts the idle lever, and ON when it contacts the full speed lever.

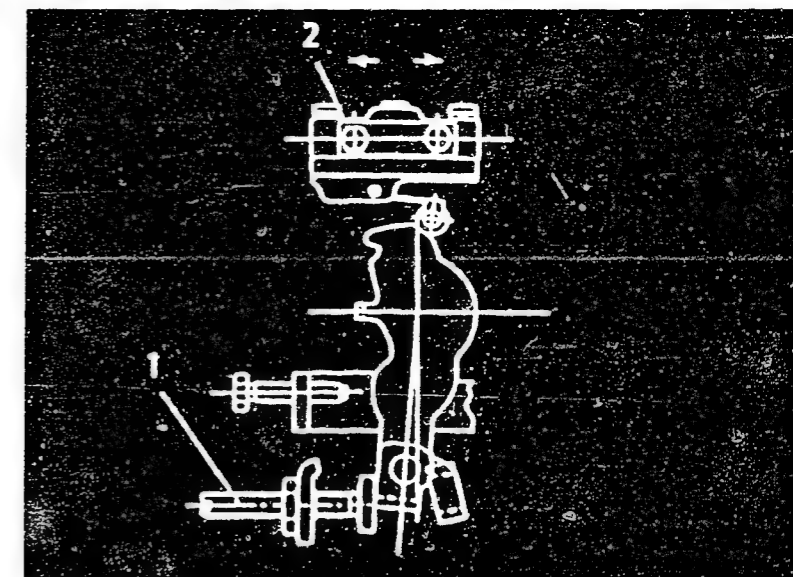

Figure 18

- 1 = Adjusting screw
- 2 = Micro switch fix bolt
(T = 0.2 - 0.3 kg-m)



Test oil:
ISO 4113 or
SAE J967d

ZEXEL-TEST VALUES
Distributor pumps
Engine model: 4JB1CDT

BOSCH No. 9 460 610 455
ZEXEL No. 104741-5260
Date: 31.01.1991 [0]
Company: ISUZU
No. 89702 83290

Injection pump no.: 104641-5250

(NP-VE4/11F1900RNP578)

Pump rot.: clockwise-viewed from drive side

Test-nozzle holder combination:
1 688 901 000

Test pressure line:
1 680 750 017

1. Setting values		Speed (rpm)	Setting values	Charge-air pressure bar (mmHg)	Difference in delivery (cc)
1-1	Time device travel	1700	5.0 - 5.4 (mm)	590 - 610	
1-2	Supply pump pressure	1700	5.2 - 5.6 (kg/cm ²)	590 - 610	
1-3	Full load delivery	1250 (Full)	60.0 - 61.0 (cc/1000st)	590 - 610	3.5
	Full load delivery	900 (BCS)	48.3 - 49.3 (cc/1000st)	340 - 360	4.5
1-4	Idle speed regulation	385	3.1 - 7.1 (cc/1000st)	0	2.0
1-5	Start	100	60.0 - 100.0(cc/1000st)	0	
1-6	Full-load speed regulation	2300	19.3 - 25.3 (cc/1000st)	590 - 610	4.5

2. Test values

2-1 Timing device	Solenoid timer N = rpm mm	ON		OFF	
		550 above 0.5	1450	1700	1850
			1.9 - 3.1	4.9 - 5.5	5.8 - 6.6
2-2 Supply pump	N = rpm kg/cm ²			1700	1850
				5.2 - 5.6	5.6 - 6.2
2-3 Overflow delivery	N = rpm cc/10s	1700		1700	
		60.0 - 120.0		93 - 203	

2-4 Fuel delivery quantities

Speed control lever pos.	Speed (rpm)	Fuel delivery (cc/1000st)	Charge-air pres(mmHg)	Difference in delivery (cc)
End stop	1250 (Full)	59.5 - 61.5	590 - 610	
	900 (BCS)	47.8 - 49.8	340 - 360	
	600	30.3 - 40.3	90 - 110	
	750	36.7 - 42.7	170 - 190	
	1250	33.3 - 41.3	0	
	1800	50.7 - 59.7	590 - 610	
	2300	18.8 - 25.8	590 - 610	
	2400	below 15.0	590 - 610	
2500	below 5.0	590 - 610		
Switch off	385	0	0	
Idle-stop	500	below 3.0	0	
	385	3.1 - 7.1	0	
2-5 Solenoid	Cut-in voltage max.: 8 V Test voltage: 12 - 14 V			

3. Dimensions

K	2.7 - 2.9 mm
KF	5.4 - 5.6 mm
MS	0.8 - 1.0 mm
BCS	4.4 - 4.6 mm
Prest.	0.43 - 0.47 mm

Control lever angle

α	14 - 22° deg
A	11.3 - 14.7 mm
β	32 - 42° deg
B	10.2 - 13.6 mm
γ	- deg
C	- mm

E12

ZEXEL - Test values
Injection pumps



E13

ZEXEL - Test values
Injection pumps



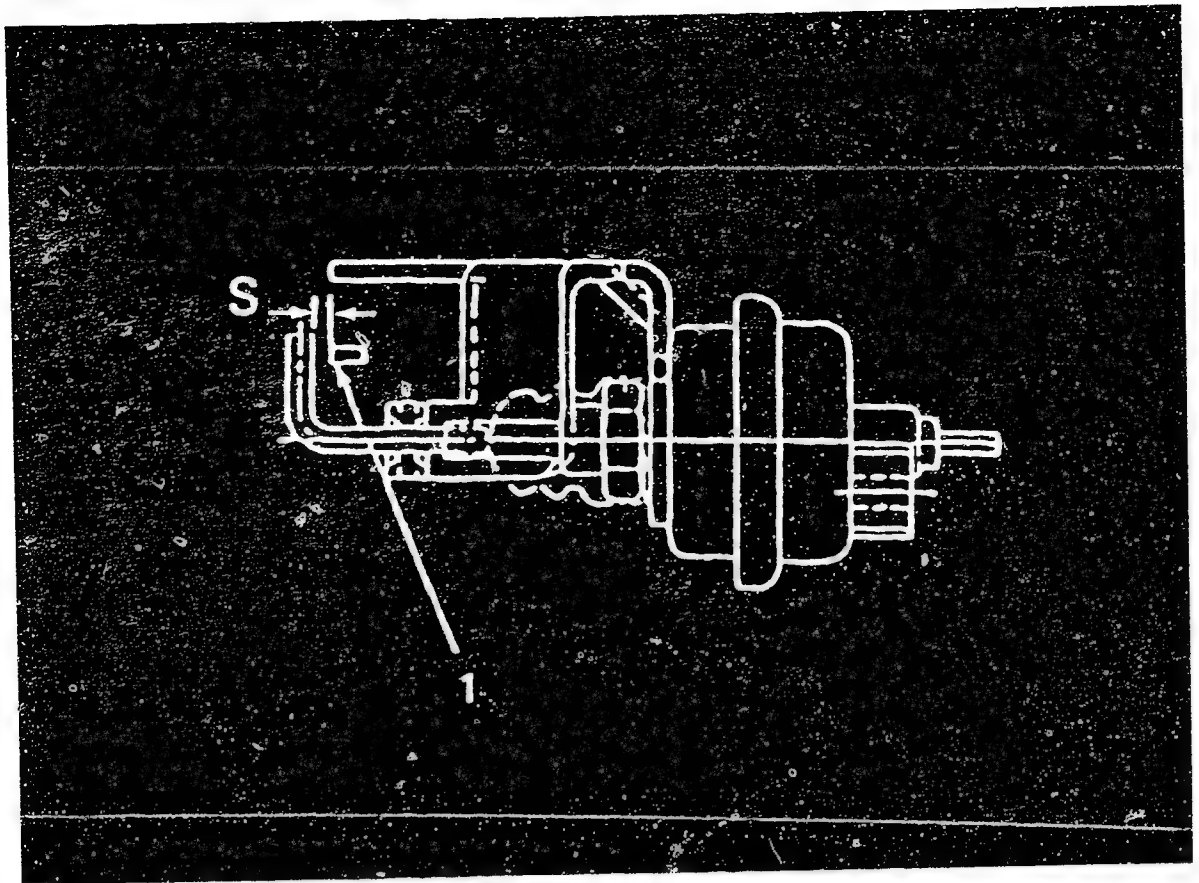

Figure 19

104741-5260 2/3

1 = Control lever
(Idling position)

■ V-FICD ADJUSTMENT

1. Adjust the bracket so that the clearance S is 1^{+1} mm.
2. Apply 400 mmHg negative pressure to the inside of the actuator and confirm that the actuator shaft moves the full stroke.

E14

ZEXEL - Test values

Injection pumps



Injection quantity specifications Boost pressure=600mmHg(0.81 kg/cm ²)	
I/P speed (rpm)	Injection quantity (mm ³ /1000st)
1000	26.9 - 28.9

1. Fix the dummy bolt in a position where pump speed is 1000 rpm and injection quantity is 26.9 - 28.9.
2. Move the microswitch in the direction of the arrow from the ON to the OFF position and fix it in this position.
3. Remove the dummy bolt's fixing bracket and confirm that the microswitch is OFF when it contacts the idle lever, and ON when it contacts the full speed lever.

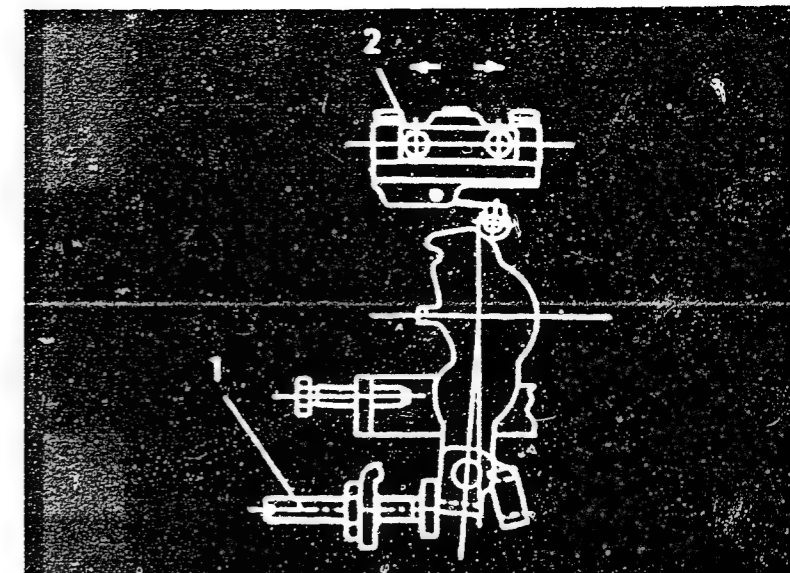

Figure 20

- 1 = Adjusting screw
- 2 = Micro switch fix bolt
(T = 0.2 - 0.3 kg-m)



Test oil:
ISO 4113 or
SAE J967d

ZEXEL-TEST VALUES
Distributor pumps
Engine model: 4JB1-TC

BOSCH No. 9 460 610 449
ZEXEL No. 104741-6831
Date: 31.01.1991 [0]
Company: ISUZU
No. 89701 09441

Injection pump no.: 104641-6353 (NP-VE4/11F1900RNP773)

Pump rot.: clockwise-viewed from drive side Test-nozzle holder combination: 1 688 901 022 Test pressure line: 1 680 750 073

1. Setting values		Speed (rpm)	Setting values	Charge-air pressure bar (mmHg)	Difference in delivery (cc)
1-1	Time device travel	1500	4.9 - 5.3 (mm)	590 - 610	
1-2	Supply pump pressure	1500	4.7 - 5.1 (kg/cm ²)	590 - 610	
1-3	Full load delivery	1250 (Full)	68.1 - 69.1 (cc/1000st)	590 - 610	3.5
	Full load delivery	800 (BCS)	47.7 - 48.7 (cc/1000st)	295 - 315	4.5
1-4	Idle speed regulation	385	6.1 - 10.1 (cc/1000st)	0	2.0
1-5	Start	100	80.0 - 90.0 (cc/1000st)	0	
1-6	Full-load speed regulation	2300	16.6 - 22.6 (cc/1000st)	590 - 610	4.5

2. Test values					
2-1 Timing device	Solenoid timer	ON	OFF		
	N = rpm mm	750 above 1.0	1500 4.8 - 5.4	1700 6.5 - 7.7	1900 8.2 - 9.0
2-2 Supply pump	N = rpm kg/cm ²		1500 4.7 - 5.1		1900 5.8 - 6.4
2-3 Overflow delivery	N = rpm cc/10s	1500 57.0 - 100.0	1500 65 - 108		
2-4 Fuel delivery quantities					
Speed control lever pos.	Speed (rpm)	Fuel delivery (cc/1000st)	Charge-air pres (mmHg)	Difference in delivery (cc)	
End stop	1250 (Full)	67.6 - 69.6	590 - 610		
	800 (BCS)	47.2 - 49.2	295 - 315		
	400	36.5 - 47.5	0		
	600	34.7 - 40.7	130 - 150		
	1250	47.6 - 54.6	0		
	1900	66.5 - 75.5	590 - 610		
	2300	16.1 - 23.1	590 - 610		
	2400	below 12.0	590 - 610		
Switch off	385	0	0		
Idle-stop	385	6.1 - 10.1	0		
	500	below 3.0	0		
2-5 Solenoid	Cut-in voltage max.: 8 V Test voltage: 12 - 14 V				

3. Dimensions	
K	2.7 - 2.9 mm
KF	5.4 - 5.6 mm
MS	0.9 - 1.1 mm
BCS	3.8 - 4.0 mm
Prest.	0.43 - 0.47 mm
Control lever angle	
α	20 - 28° deg
A	- mm
β	43 - 53° deg
B	- mm
γ	- deg
C	- mm



Adjustment Conditions			Specified Value	Remarks
Control lever position	Pump speed (rpm)	Fuel injection quantity (cc/1000st)	Out-put voltage (V)	
approx.	750	7.7 - 9.7 Boost= 600mmHg	2.46 - 2.52	Adjust. point
Idle	385	6.1 - 10.1	0.56 - 1.36	Check point
Full speed	-	-	-	Check point

(In-put voltage: 10V)

1. At a pump speed of 750 rpm and a fuel injection quantity of 7.7 - 9.7 cc/1000st, adjust the dummy bolt so that it contacts the control lever, and then fix it using the locknut.
2. Then, adjust the potentiometer so that the output voltage is 2.46 - 2.76 V.
3. Following adjustment, remove the dummy bolt and confirm that the potentiometer output voltage is as specified above when the control lever is in the idle position.



Injection quantity specifications (Boost pressure = 600 mmHg)		Microswitch adjustment specifications	
Speed (rpm)	Injection quantity (mm ³ /st)	Microswitch operation	Potentiometer output (V)
1000	47.1 - 54.1	ON → OFF	4.51 - 4.61

1. Fix the dummy bolt used to adjust the potentiometer so that potentiometer output voltage is 4.56 V.
2. Move the microswitch in the direction of the arrow from the ON position of the OFF position, and fix it in this position.
3. Loosen the dummy bolt and confirm that potentiometer output voltage is 4.51 - 4.61V when the microswitch moves from ON to OFF.
4. Following adjustment, remove the dummy bolt's fixing bracket.

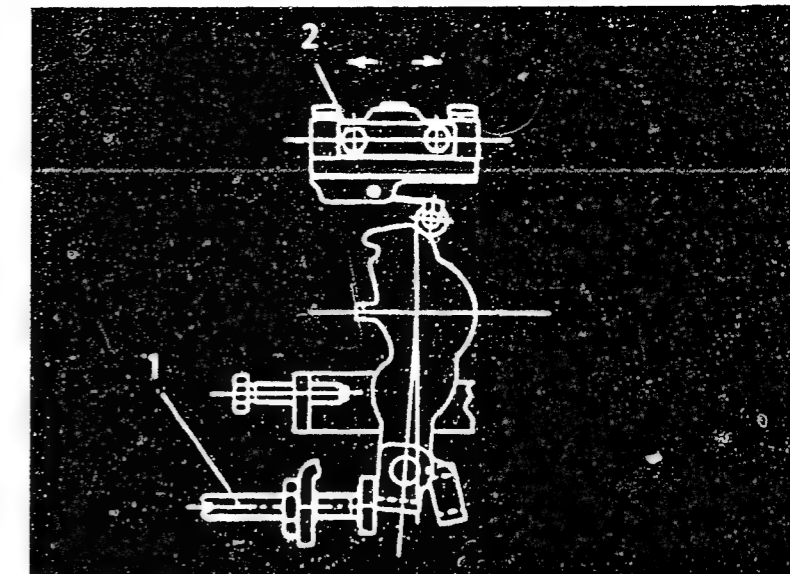

Figure 21

- 1 = Adjusting screw
- 2 = Microswitch fixing bolt
T = 0.2 - 0.3 kgm



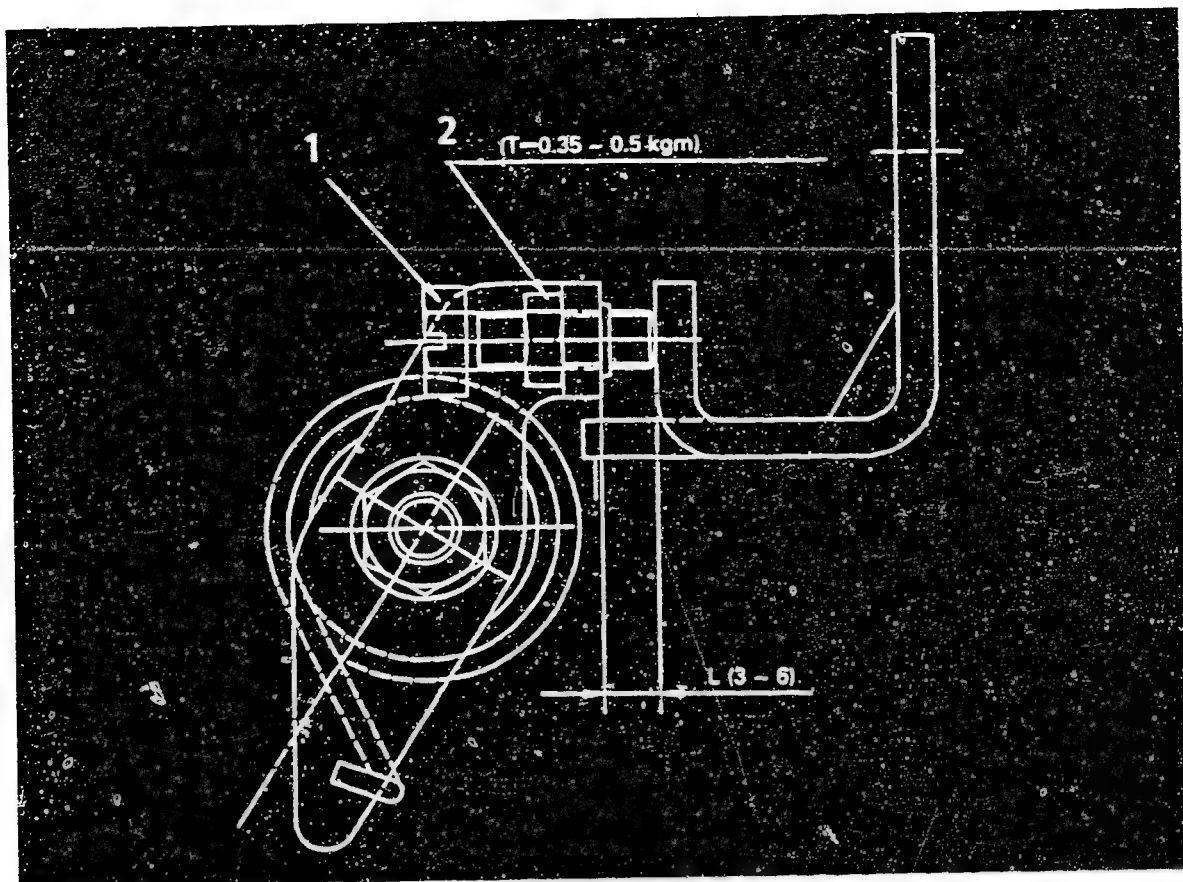

Figure 22

104741-6352 4/4

- 1 = Bolt
- 2 = Nut

■ V-FICD ADJUSTMENT

1. Adjust the bracket so that the clearance S is 1^{+1} mm.
2. Apply 400 mmHg negative pressure to the inside of the actuator and confirm that the actuator shaft moves the full stroke.

■ STARTING INJECTION QUANTITY ADJUSTMENT

Adjust the starting injection quantity (page 1/4) using the adjusting bolt (Fig. 22).

E23

ZEXEL - Test values

Injection pumps



Test oil:
ISO 4113 od
SAE J967d

ZEXEL - TEST VALUES
Distributors pumps
Engine model: 4FB1

BOSCH No. 9 460 610 450
ZEXEL No. 104748-1000
Date: 31.01.1991 (1)
Company: ISUZU
No. 89422 52461

Injection pump no. 104648-1040

(NP-VE4/8F2500RNP23)

Pump rot.: clockwise-viewed from drive side

Test-nozzle holder combination:
1 688 901 000

Test pressure line:
1 680 750 017

1. Setting values		Pump speed (rpm)	Setting values	Charge-air pressure bar (mmHg)	Difference in delivery (cc)
1-1	Timing device travel	1400	2.4 - 2.8 (mm)		
1-2	Supply pump pressure	1400	4.7 - 5.1 (kg/cm ²)		
1-3	Full load delivery	1250	30.7 - 31.7 (cc/1000st)		2.5
	Full load delivery		(cc/1000st)		
1-4	Idle speed regulation	315	5.5 - 9.5 (cc/1000st)		2.0
1-5	Start	100	above 40.0 (cc/1000st)		
1-6	Full-load speed regulation	2750	12.0 - 18.0 (cc/1000st)		
1-7	CSD Adjustment	600 - 800	Release speed		
1-8					

2. Test values

2-1 Timing device	N = rpm	1400	2000	2750
	mm	2.3 - 2.9	4.3 - 5.5	6.9 - 7.8
2-2 Supply pump	N = rpm	1000	1400	2500
	kg/cm ²	3.5 - 4.1	4.7 - 5.1	7.4 - 8.0
2-3 Overflow delivery	N = rpm	1400		
	cc/10s	58.0 - 102.0		

2-4 Fuel injection quantities

Control lever position	Pump speed (rpm)	Fuel delivery (cc/1000 strokes)	Charge-air pres (mmHg)	Difference in delivery (cc)
End stop	1250	30.2 - 32.2		
	600	25.4 - 29.4		
	2500	28.2 - 32.2		
	2750	12.0 - 18.0		
	3000	below 4.0		
Switch off	315	0		
Idle stop	315	5.5 - 9.5		
	500	0		
CSD Adjustment	0	2.3 - 2.7		
	600 - 800	Release speed		

2-5 Solenoid
Cut-in voltage max.: 8 V
Test voltage: 12 - 14 V

3. Dimensions

K	3.2 - 3.4 mm
KF	5.7 - 5.9 mm
MS	1.5 - 1.7 mm
BCS	- mm
Pre-str.	- mm

Control lever angle

α	21.0 - 29.0 deg
A	- mm
β	33.0 - 43.0 deg
B	- mm
γ	- deg
C	- mm

E24

ZEXEL - Test values
Injection pumps



E25

ZEXEL - Test values
Injection pumps



Test oil:
ISO 4113 od
SAE J967d

ZEXEL - TEST VALUES
Distributors pumps
Engine model:4FB1

BOSCH No. 9 460 610 451
ZEXEL No. 104748-1010
Date: 31.01.1991 [0]
Company: ISUZU
No. 89422 52471

Injection pump no. 104648-1040

(NP-VE4/8F2500RNP23)

Pump rot.: clockwise-viewed from drive side

Test-nozzle holder combination:
1 688 901 000

Test pressure line:
1 680 750 017

1. Setting values		Pump speed (rpm)	Setting values	Charge-air pressure bar (mmHg)	Difference in delivery (cc)
1-1	Timing device travel	1400	2.4 - 2.8 (mm)		
1-2	Supply pump pressure	1400	4.7 - 5.1 (kg/cm ²)		
1-3	Full load delivery	1250	30.7 - 31.7 (cc/1000st)		2.5
	Full load delivery		(cc/1000st)		
1-4	Idle speed regulation	315	5.5 - 9.5 (cc/1000st)		2.0
1-5	Start	100	above 40.0 (cc/1000st)		
1-6	Full-load speed regulation	2750	12.0 - 18.0 (cc/1000st)		
1-7	CSD Adjustment	600 - 800	Release speed		
1-8					

2. Test values

2-1 Timing device	N = rpm mm	1400 2.3 - 2.9	2000 4.3 - 5.5	2750 6.9 - 7.8
2-2 Supply pump	N = rpm kg/cm ²	1000 3.5 - 4.1	1400 4.7 - 5.1	2500 7.4 - 8.0
2-3 Overflow delivery	N = rpm cc/10s		1400 58.0 - 102.0	

2-4 Fuel injection quantities

Control lever position	Pump speed (rpm)	Fuel delivery (cc/1000 strokes)	Charge-air pres (mmHg)	Difference in delivery (cc)
End stop	1250	30.2 - 32.2		
	600	25.4 - 29.4		
	2500	28.2 - 32.2		
	2750	12.0 - 18.0		
	3000	below 4.0		
Switch off	315	0		
Idle stop	315	5.5 - 9.5		
	500	0		
CSD Adjustment	0	2.3 - 2.7 mm		
	600 - 800	Release speed		

2-5 Solenoid
Cut-in voltage max.: 8 V
Test voltage: 12 - 14 V

3. Dimensions

K 3.2 - 3.4 mm
KF 5.7 - 5.9 mm
MS 1.5 - 1.7 mm
BCS - mm
Pre-str. - mm

Control lever angle

α 21.0 - 29.0 deg
A - mm
 β 33.0 - 43.0 deg
B - mm
 γ - deg
C - mm

E26

ZEXEL - Test values
Injection pumps



E27

ZEXEL - Test values
Injection pumps



Test oil:
ISO 4113 od
SAE J967d

ZEXEL - TEST VALUES
Distributors pumps
Engine model: LD20

BOSCH No. 9 460 610 457
ZEXEL No. 104749-2153
Date: 31.01.1991 [0]
Company: NISSAN
No. 16700 43S00

Injection pump no. 104649-2123

(NP-VE4/9F2500RNP20)

Pump rot.: clockwise-viewed from drive side

Test-nozzle holder combination:
1 688 901 000

Test pressure line:
1 680 750 017

1. Setting values		Pump speed (rpm)	Setting values	Charge-air pressure bar (mmHg)	Difference in delivery (cc)
1-1	Timing device travel	900	1.1 - 1.7 (mm)		2.5
1-2	Supply pump pressure	900	2.9 - 3.5 (kg/cm ²)		
1-3	Full load delivery	900	32.5 - 33.5 (cc/1000st)		
	Full load delivery		(cc/1000st)		
1-4	Idle speed regulation	325	6.7 - 9.7 (cc/1000st)		
1-5	Start	100	above 52.0 (cc/1000st)		
1-6	Full-load speed regulation	2700	7.2 - 13.2 (cc/1000st)		
1-7					
1-8					

2. Test values

2-1 Timing device	N = rpm mm	900 1.0 - 1.8	1800 4.5 - 5.7	2300 6.9 - 7.8
2-2 Supply pump	N = rpm kg/cm ²	900 2.8 - 3.6	1800 4.9 - 5.7	2300 6.2 - 7.0
2-3 Overflow delivery	N = rpm cc/10s	1000 36.0 - 80.0		

2-4 Fuel injection quantities

Control lever position	Pump speed (rpm)	Fuel delivery (cc/1000 strokes)	Charge-air pres (mmHg)	Difference in delivery (cc)
End stop	900	32.0 - 34.0	2.5	
	600	31.2 - 35.2		
	2300	30.6 - 34.6		
	2700	6.7 - 13.7		
	2800	below 6.0		
Switch off	325	0		
Idle stop	325	6.0 - 10.2	2.5	
	500	below 4.0		
Partial load	900	5.0 - 15.0		

2-5 Solenoid
Cut-in voltage max.: 8 V
Test voltage: 12 - 14 V

3. Dimensions

K 3.2 - 3.4 mm
KF 5.7 - 5.9 mm
MS 1.1 - 1.3 mm
BCS - mm
Pre-str. - mm

Control lever angle

α 56.0 - 60.0 deg
A 8.9 - 13.2 mm
β 36.0 - 46.0 deg
B 11.0 - 14.5 mm
γ 10.5 - 11.5 deg
C 6.7 - 7.3 mm

F1

ZEXEL - Test values
Injection pumps



F2

ZEXEL - Test values
Injection pumps



Test oil:
ISO 4113 od
SAE J967d

ZEXEL - TEST VALUES
Distributors pumps
Engine model: LD20

BOSCH No. 9 460 610 389
ZEXEL No. 104749-2160
Date: 31.01.1991 [0]
Company: NISSAN
No. 16700 79700

Injection pump no. 104649-2160

(NP-VE4/9F2000RNP325)

Pump rot.: clockwise-viewed from drive side

Test-nozzle holder combination:
1 688 901 000

Test pressure line:
1 680 750 017

1. Setting values		Pump speed (rpm)	Setting values	Charge-air pressure bar (mmHg)	Difference in delivery (cc)
1-1	Timing device travel	900	1.1 - 1.7 (mm)		
1-2	Supply pump pressure	900	2.9 - 3.5 (kg/cm ²)		
1-3	Full load delivery	900	32.5 - 33.5 (cc/1000st)		2.5
	Full load delivery		(cc/1000st)		
1-4	Idle speed regulation	325	6.7 - 9.7 (cc/1000st)		3.0
1-5	Start	100	above 52.0 (cc/1000st)		
1-6	Full-load speed regulation	2200	6.6 - 12.6 (cc/1000st)		
1-7					
1-8					

2. Test values

2-1 Timing device	N = rpm	900	2000
	mm	1.0 - 1.8	5.2 - 6.4
2-2 Supply pump	N = rpm	900	2000
	kg/cm ²	2.8 - 3.6	5.4 - 6.2
2-3 Overflow delivery	N = rpm	900	
	cc/10s	35.0 - 79.0	

2-4 Fuel injection quantities

Control lever position	Pump speed (rpm)	Fuel delivery (cc/1000 strokes)	Charge-air pres (mmHg)	Difference in delivery (cc)
End stop	900	32.0 - 34.0		
	600	31.2 - 35.2		
	2000	28.2 - 35.2		
	2200	6.1 - 13.1		
	2350	below 6.0		
Switch off	325	0		
Idle	325	6.0 - 10.2		
stop	500	below 4.0		

2-5 Solenoid
Cut-in voltage max.: 8 V
Test voltage: 12 - 14 V

3. Dimensions

K 3.2 - 3.4 mm
KF 5.7 - 5.9 mm
MS 1.1 - 1.3 mm
BCS - mm
Pre-str. - mm

Control lever angle

α 16.0 - 24.0 deg
A 5.7 - 10.9 mm
 β 35.0 - 45.0 deg
B 10.6 - 14.5 mm
 γ - deg
C - mm

F3

ZEXEL - Test values
Injection pumps



F4

ZEXEL - Test values
Injection pumps



Test oil:
ISO 4113 od
SAE J967d

ZEXEL - TEST VALUES
Distributors pumps
Engine model: C223

BOSCH No. 9 460 610 458
ZEXEL No. 104749-6981
Date: 31.01.1991 [0]
Company: ISUZU
No. 89447 51860

Injection pump no. 104649-6971

(NP-VE4/9F2175RNP676)

Pump rot.: clockwise-viewed from drive side

Test-nozzle holder combination:
1 688 901 000

Test pressure line:
1 680 750 017

1. Setting values		Pump speed (rpm)	Setting values	Charge-air pressure bar (mmHg)	Difference in delivery (cc)
1-1	Timing device travel	1500	4.2 - 4.6 (mm)		
1-2	Supply pump pressure	1500	5.2 - 5.6 (kg/cm ²)		
1-3	Full load delivery	1250	35.8 - 36.8 (cc/1000st)		3.0
	Full load delivery		(cc/1000st)		
1-4	Idle speed regulation	375	5.6 - 9.6 (cc/1000st)		2.0
1-5	Start	100	above 63.0 (cc/1000st)		
1-6	Full-load speed regulation	2550	7.8 - 13.8 (cc/1000st)		3.0
1-7	CSD Adjustment	500 - 700	Release speed		
1-8					

2. Test values

2-1 Timing device	N = rpm	1000	1500	2175
	mm	1.6 - 2.8	4.1 - 4.7	7.0 - 7.8
2-2 Supply pump	N = rpm	1000	1500	2175
	kg/cm ²	3.8 - 4.4	5.2 - 5.6	6.6 - 7.2
2-3 Overflow delivery	N = rpm	1000		
	cc/10s	48.0 - 92.0		

2-4 Fuel injection quantities

Control lever position	Pump speed (rpm)	Fuel delivery (cc/1000 strokes)	Charge-air pres (mmHg)	Difference in delivery (cc)
End stop	1250	35.3 - 37.3		
	600	32.0 - 36.2		
	2550	7.3 - 14.3		
	2700	below 3.5		
Switch off	375	0		
Idle stop	375	5.5 - 9.6		
	500	below 3.0		
CSD Adjustment	0	2.7 - 3.1 mm		
	500 - 700	Release speed		

2-5 Solenoid
Cut-in voltage max.: 8 V
Test voltage: 12 - 14 V

3. Dimensions

K 3.2 - 3.4 mm
KF 5.7 - 5.9 mm
MS 1.7 - 1.9 mm
BCS - mm
Pre-str. - mm

Control lever angle

α 21.0 - 29.0 deg
A 9.6 - 12.2 mm
 β 37.0 - 47.0 deg
B 11.9 - 15.1 mm
 γ - deg
C - mm

F5

ZEXEL - Test values
Injection pumps



F6

ZEXEL - Test values
Injection pumps



Test oil
ISO 4113 or
SAE J967d

ZEXEL - TEST VALUES
Distributor pumps
Engine model: LD28

BOSCH No. 9 460 610 452
ZEXEL No. 104760-2143
Date: 31.01.1991 [0]
Company: NISSAN
No. 16700 28L62

Injection pump no.: 104660-2093

(NP-VE6/10F2500RNP1)

Pump rot.: Clockwise-viewed from drive side

Test-nozzle holder combination:
1 688 901 000

Test pressure line:
1 680 750 017

1. Setting values		Pump speed (rpm)	Setting values	Charge-air pressure bar (mmHg)	Difference in delivery (cc)	
1-1	Timing device travel	1200	2.4 - 3.0 (mm)		2.5	
1-2	Supply pump pressure	1800	5.7 - 6.3 (kg/cm ²)			
1-3	Full load delivery	1200	29.6 - 30.6 (cc/1000st)			
	Full load delivery		- (cc/1000st)			
1-4	Idle speed regulation	350	6.7 - 9.7 (cc/1000st)			3.0
1-5	Start	100	above 47.0 (cc/1000st)			
1-6	Full-load speed regulation	2700	7.0 - 13.0 (cc/1000st)			
1-7	Load-timer adjustment					

2. Test values

2-1 Timing device	N = rpm		1200	1800	2300	
	mm		2.3-3.1	4.8-6.0	7.7-8.6	
2-2 Supply pump	N = rpm	800	1800	2500		
	kg/cm ²	3.3-4.1	5.6-6.4	7.1-7.9		
2-3 Overflow delivery	N = rpm	1000				
	cc/10s	53.0-97.0				

2-4 Fuel injection quantities

Speed control lever pos.	Pump speed (rpm)	Fuel delivery (cc/1000st)	Charge-air pres (mmHg)	Difference in delivery (cc)
End stop	1200	29.1 - 31.1		
	600	22.3 - 26.3		
	2300	25.1 - 29.1		
	2700	6.5 - 13.5		
	2800	below 5.0		
Switch off	350	0		
Idle-stop	350	6.2 - 10.2		
	500	below 4.0		
Partial load	900	11.0 - 21.0		

2-5 Solenoid
Cut-in voltage max.: 8 V
Test voltage: 12 - 14 V

3. Dimensions

K 3.2 - 3.4 mm
KF 6.54 - 6.74 mm
MS 1.7 - 1.9 mm
BCS - mm
Pre-st. - mm

Control lever angle

α 21 - 29 deg
A 2.5 - 8.0 mm
 β 39 - 49 deg
B 11.0 - 16.0 mm
 γ 10.5 - 11.5 deg
C 6.7 - 7.3 mm

F7

ZEXEL - Test values
Injection pumps



F8

ZEXEL - Test values
Injection pumps



Test oil ISO 4113 or SAE J967d	ZEXEL - TEST VALUES Distributor pumps Engine model: RD28-T	BOSCH No. 9 460 610 423 ZEXEL No. 104769-2152 Date: 31.01.1991 [1] Company: NISSAN No. 16700 22J00
Injection pump no.: 104669-2151	(NP-VE6/9F2300RNP57)	

Pump rot.: Clockwise-viewed from drive side	Test-nozzle holder combination: 1 688 901 022	Test pressure line: 1 680 750 073
---	--	--------------------------------------

1. Setting values	Pump speed (rpm)	Setting values	Charge-air pressure bar (mmHg)	Difference in delivery (cc)
1-1 Timing device travel	900	1.1 - 1.5 (mm)	342 - 362	
1-2 Supply pump pressure	900	3.5 - 4.1 (kg/cm ²)	342 - 362	
1-3 Full load delivery	600 (Full)	31.3 - 32.1 (cc/1000st)	0	2.0
Full load delivery	900 (BCS)	38.6 - 39.4 (cc/1000st)	240 - 260	2.0
1-4 Idle speed regulation	350	6.6 - 8.6 (cc/1000st)	0	0.9
1-5 Start	100	above 38.0 (cc/1000st)	0	
1-6 Full-load speed regulation	2350	35.3 - 37.3 (cc/1000st)	470 - 490	4.5
1-7 Load-timer adjustment				

2. Test values

2-1 Timing device	N = rpm	900	1800	2300	2500	
	mm	1.1-1.5	4.3-5.4	6.3-7.4	6.5-7.4	
2-2 Supply pump	N = rpm	900	1800	2300		
	kg/cm ²	3.5-4.1	5.6-6.2	6.9-7.5		
2-3 Overflow delivery	N = rpm	900				
	cc/10s	43.0-87.0				

2-4 Fuel injection quantities

Speed control lever pos.	Pump speed (rpm)	Fuel delivery (cc/1000st)	Charge-air pres (mmHg)	Difference in delivery (cc)
End stop	600 (Full)	30.8 - 32.6	0	
	900 (BCS)	38.1 - 39.9	240 - 260	
	1200	42.0 - 46.0	470 - 490	
	1800	41.2 - 45.2	470 - 490	
	2200	40.5 - 46.5	470 - 490	
	2300	37.8 - 44.8	470 - 490	
	2350	34.8 - 37.8	470 - 490	
	2500	14.0 - 24.0	470 - 490	
Switch off	350	0	0	
	900	0	342 - 362	
Idle-stop	350	6.6 - 8.6	0	
	500	below 3.0	0	
Partial load	900	6.6 - 12.6	0	

2-5 Solenoid	Cut-in voltage max. 8 V Test voltage: 12 - 14 V
--------------	--

3. Dimensions

K	3.2 - 3.4 mm
KF	6.54 - 6.74 mm
MS	1.7 - 1.9 mm
BCS	3.8 - 4.0 mm
Pre-st.	- mm
Control lever angle	
α	19 - 27° deg
A	8.7 - 12.9 mm
β	37 - 47° deg
B	11.5 - 15.2 mm
γ	10.5 - 11.5 deg
C	5.7 - 6.3 mm

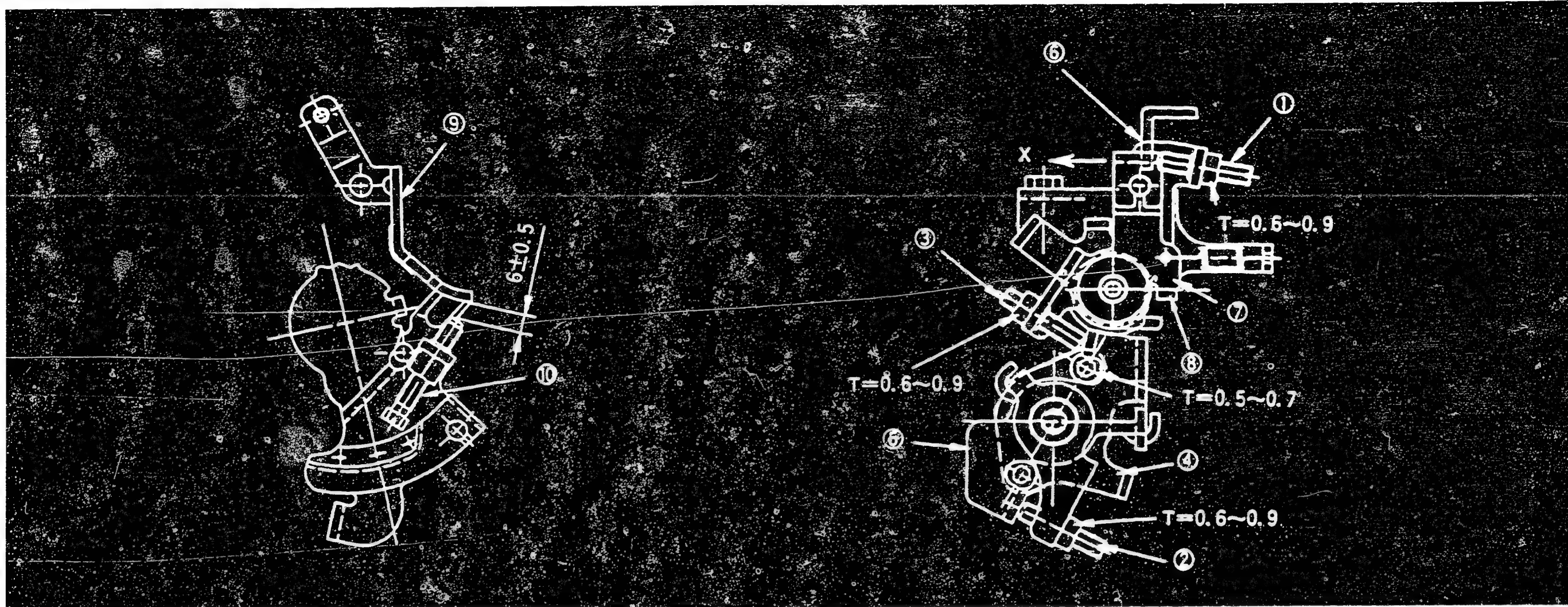

9 = Idling set bracket
10 = Screw

Figure 23
1 = Screw
2 = Screw
3 = Screw
4 = Stopper

5 = CSD lever
6 = Control lever
7 = Intermediate lever
8 = Stopper

104769-2152 2/3

■ M-CSD ADJUSTMENT

1. CSD Adjustment

- 1) Hold the control lever (6) in the idling position.
- 2) Move the CSD lever (5) to the right until it contacts the stopper (4).
- 3) Then, adjust the position of the screw (2) so that the timer stroke is 1.6 ± 0.2 mm and fix the screw (2) using the nut.

F11

ZEXEL - Test values
Injection pumps



F12

ZEXEL - Test values
Injection pumps



(Continued)

2. Fixing the Intermediate Lever Adjustment Screw

- 1) Hold the CSD lever (5) in the position described in item 1 (timer stroke: 1.6 ± 0.2 mm).
- 2) Move the intermediate lever (7) toward 'X' and confirm that it contacts the stopper (8).
- 3) Then, adjust the screw (3) so that the CSD lever (5) contacts the screw (3) and fix the screw (3) using the nut.
- 4) Return the intermediate lever (7) to its original position and confirm that the timer stroke is 0 mm.

3. Screw (1) Adjustment

- 1) Move the intermediate lever (7) toward 'X' until it contacts the stopper (8).
- 2) Adjust the position of the screw (1) so that the gap between the idling set bracket (9) and screw (10) is 6 ± 0.5 mm, and fix the screw (1) using the nut.
- 3) Then, confirm that the gap between the control lever (6) and screw (1) is approximately 1.7 mm.

F13

ZEXEL - Test values

Injection pumps



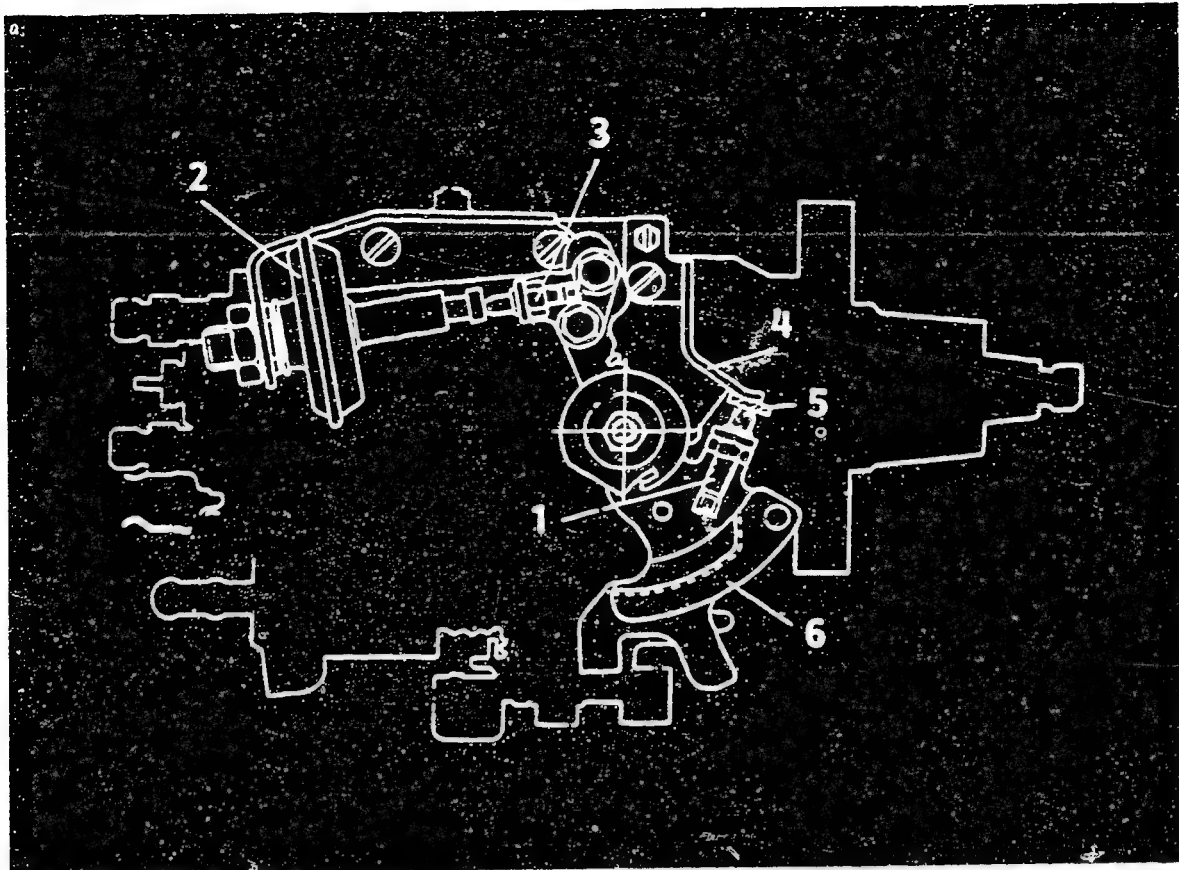

Figure 24

104769-2152 3/3

- | | |
|------------------------------|-------------------|
| 1 = Idling stopper bolt | 4 = Bracket |
| 2 = Dash pot | 5 = Block gauge |
| 3 = Dash pot adjusting screw | 6 = Control lever |

■ DASH POT ADJUSTMENT

1. Insert a block gauge (thickness gauge) of thickness 3.8 ± 0.05 mm in the gap between the idling stopper bolt and the bracket.
2. With the control lever positioned as described in 1. above, adjust the dashpot adjusting screw so that the dashpot adjusting screw and the pushrod are in contact. Fix the screw using the nut.



Test oil
ISO 4113 or
SAE J967d

ZEXEL - TEST VALUES
Distributor pumps
Engine model: RD28

1/3

BOSCH No.	9 460 610 440
ZEXEL No.	104769-2172
Date:	31.01.1991 [0]
Company:	NISSAN
No.	16700 C9600

Injection pump no.: 104669-2172

(NP-VE6/9F2500RNP59)

Pump rot.: Clockwise-viewed from drive side

Test-nozzle holder combination:
1 688 901 000

Test pressure line:
1 680 750 017

1. Setting values		Pump speed (rpm)	Setting values	Charge-air pressure bar (mmHg)	Difference in delivery (cc)
1-1	Timing device travel	900	1.0 - 1.4 (mm)		
1-2	Supply pump pressure	900	3.5 - 4.1 (kg/cm ²)		
1-3	Full load delivery	900	29.5 - 31.5 (cc/1000st)		2.5
	Full load delivery		- (cc/1000st)		
1-4	Idle speed regulation	350	5.8 - 8.8 (cc/1000st)		1.4
1-5	Start	100	above 38.0 (cc/1000st)		20
1-6	Full-load speed regulation	2600	15.5 - 21.5 (cc/1000st)		5.0
1-7	Load-timer adjustment				

2. Test values

2-1 Timing device	N = rpm mm	900 0.9-1.5	1200 2.4-3.2	2300 8.1-9.0		
2-2 Supply pump	N = rpm kg/cm ²	900 3.4-4.2	1800 5.5-6.3	2500 7.2-8.0		
2-3 Overflow delivery	N = rpm cc/10s	900 43.0-87.0				

2-4 Fuel injection quantities

Speed control lever pos.	Pump speed (rpm)	Fuel delivery (cc/1000st)	Charge-air pres (mmHg)	Difference in delivery (cc)
End stop	900	29.0 - 31.0		
	600	27.6 - 31.6		
	2300	27.3 - 31.3		
	2600	15.0 - 22.0		
	2800	below 5.0		
Switch off	350	0		
	900	0		
Idle-stop	350	5.3 - 9.3		
	500	below 4.0		

2-5 Solenoid
Cut-in voltage max. 8 V
Test voltage: 12 - 14 V

3. Dimensions

K	3.2 - 3.4 mm
KF	6.54 - 6.74 mm
MS	1.7 - 1.9 mm
BCS	- mm
Pre-st.	- mm

Control lever angle

α	19 - 27° deg
A	8.7 - 12.9 mm
β	37 - 47° deg
B	11.5 - 15.2 mm
γ	- deg
C	- mm

F15

ZEXEL - Test values
Injection pumps



F16

ZEXEL - Test values
Injection pumps



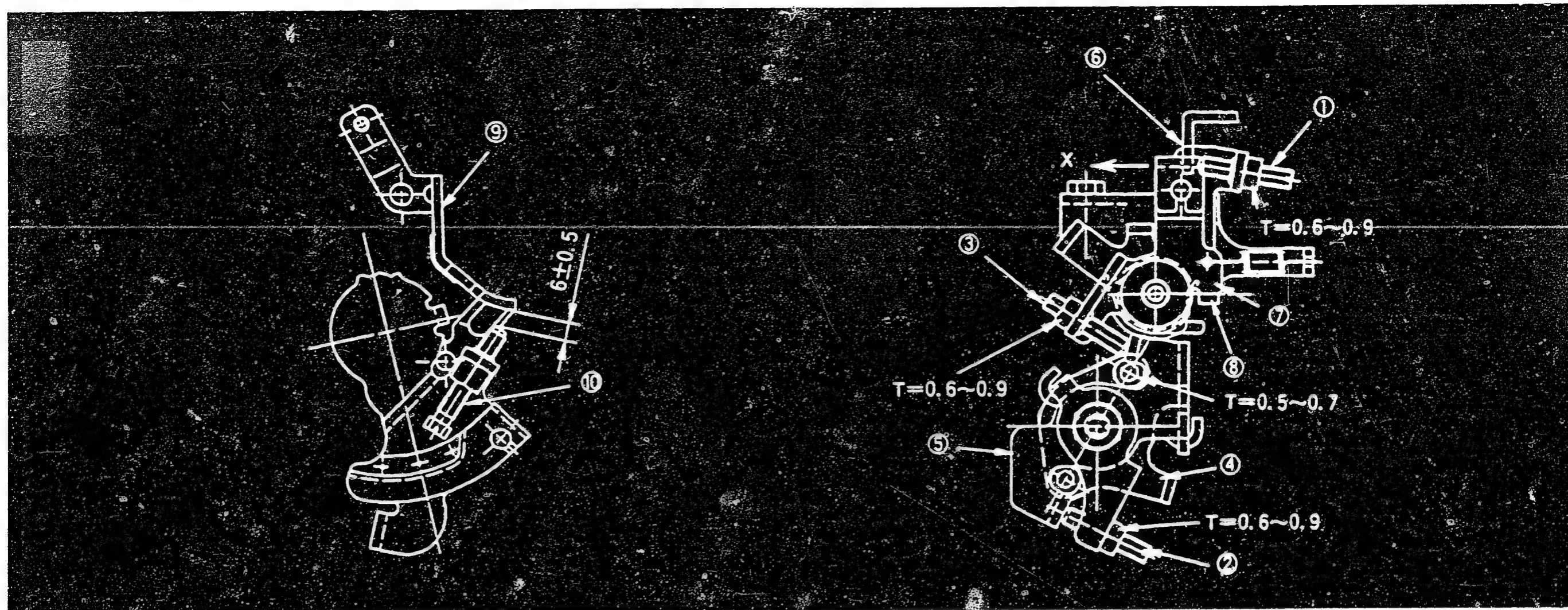

9 = Idling set bracket
10 = Screw

Figure 25
1 = Screw
2 = Screw
3 = Screw
4 = Stopper

5 = CSD lever
6 = Control lever
7 = Intermediate lever
8 = Stopper

104769-2172 2/3

■ M-CSD ADJUSTMENT

1. CSD Adjustment

- 1) Hold the control lever (6) in the idling position.
- 2) Move the CSD lever (5) to the right until it contacts the stopper (4).
- 3) Then, adjust the position of the screw (2) so that the timer stroke is 1.6 ± 0.2 mm and fix the screw (2) using the nut.



(Continued)

2. Fixing the Intermediate Lever Adjustment Screw

- 1) Hold the CSD lever (5) in the position described in item 1 (timer stroke: 1.6 ± 0.2 mm).
- 2) Move the intermediate lever (7) toward 'X' and confirm that it contacts the stopper (8).
- 3) Then, adjust the screw (3) so that the CSD lever (5) contacts the screw (3) and fix the screw (3) using the nut.
- 4) Return the intermediate lever (7) to its original position and confirm that the timer stroke is 0 mm.

3. Screw (1) Adjustment

- 1) Move the intermediate lever (7) toward 'X' until it contacts the stopper (8).
- 2) Adjust the position of the screw (1) so that the gap between the idling set bracket (9) and screw (10) is 6 ± 0.5 mm, and fix the screw (1) using the nut.
- 3) Then, confirm that the gap between the control lever (6) and screw (1) is approximately 1.7 mm.

F19

ZEXEL - Test values

Injection pumps



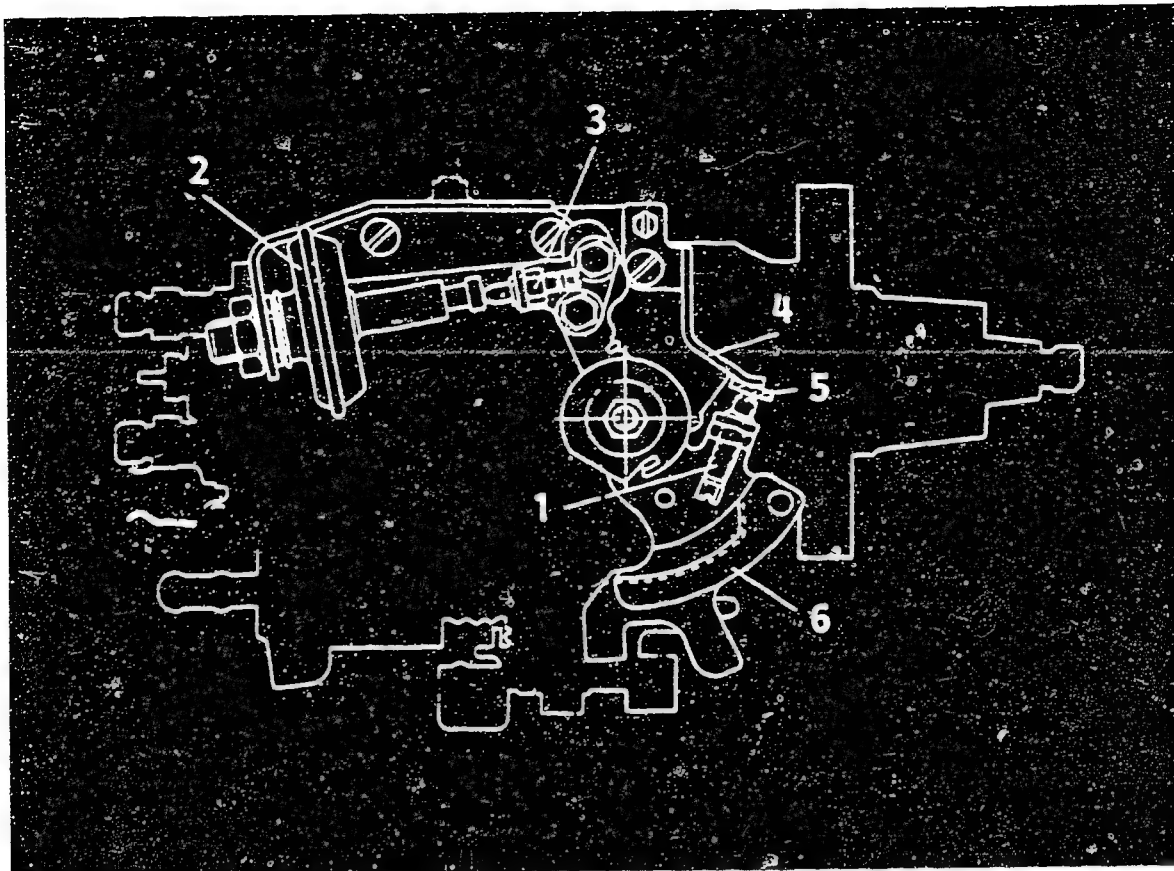

Figure 26

104769-2172 3/3

- | | |
|------------------------------|-------------------|
| 1 = Idling stopper bolt | 4 = Bracket |
| 2 = Dash pot | 5 = Block gauge |
| 3 = Dash pot adjusting screw | 6 = Control lever |

■ DASH POT ADJUSTMENT

1. Insert a block gauge (thickness gauge) of thickness 3.8 ± 0.05 mm in the gap between the idling stopper bolt and the bracket.
2. With the control lever positioned as described in 1. above, adjust the dashpot adjusting screw so that the dashpot adjusting screw and the pushrod are in contact.
Fix the screw using the nut.

Caution:

The adjusting screw and the pushrod must move together smoothly.

Confirm that the control lever returns to the idling position.



Test oil
ISO 4113 or
SAE J967d

ZEXEL - TEST VALUES
Distributor pumps
Engine model: RD28-T

BOSCH No. 9 460 610 443
ZEXEL No. 104769-2190 1/4
Date: 31.01.1991 [0]
Company: NISSAN
No. 16700 22J11

Injection pump no.: 104669-2162

(NP-VE6/9F2300RNP58)

Pump rot.: Clockwise-viewed from drive side

Test-nozzle holder combination:
1 688 901 022

Test pressure line:
1 680 750 073

1. Setting values	Pump speed (rpm)	Setting values	Charge-air pressure bar (mmHg)	Difference in delivery (cc)
1-1 Timing device travel	900	1.1 - 1.5 (mm)	342 - 362	
1-2 Supply pump pressure	900	3.5 - 4.1 (kg/cm ²)	342 - 362	
1-3 Full load delivery	600 (Full)	31.3 - 32.1 (cc/1000st)	0	2.0
Full load delivery	900 (BCS)	38.6 - 39.4 (cc/1000st)	240 - 260	2.0
1-4 Idle speed regulation	350	6.6 - 8.6 (cc/1000st)	0	0.9
1-5 Start	100	above 38.0 (cc/1000st)	0	
1-6 Full-load speed regulation	2300	34.8 - 36.8 (cc/1000st)	470 - 490	
1-7 Load-timer adjustment				

2. Test values

		Boost Pressure (mmHg) 342-362		470 - 490	
2-1 Timing device	N = rpm mm	900 1.0-1.6	1800 4.1-5.7	2300 6.1-7.4	2500 6.4-7.4
2-2 Supply pump	N = rpm kg/cm ²	900 3.5-4.1		1800 5.6-6.2	2300 6.9-7.5
2-3 Overflow delivery	N = rpm cc/10s	900 43.0-87.0			
2-4 Fuel injection quantities					
Speed control lever pos.	Pump speed (rpm)	Fuel delivery (cc/1000st)	Charge-air pres (mmHg)	Difference in delivery (cc)	
End stop	600 (Full)	30.7 - 32.7	0		
	900 (BCS)	38.0 - 40.0	240 - 260		
	1200	41.9 - 45.9	470 - 490		
	1800	40.8 - 44.8	470 - 490		
	2200	39.5 - 45.5	470 - 490		
	2300	34.3 - 37.3	470 - 490		
	2400	22.4 - 32.4	470 - 490		
2700	below 3.0	470 - 490			
Switch off	900 (Full)	0	342 - 362		
	350 (Idle)	0	0		
Idle-stop	500	below 3.0	0		
	350	6.6 - 8.6	0		
Partial load	900	10.2 - 22.2	0		
2-5 Solenoid	Cut-in voltage max. 8 V Test voltage: 12 - 14 V				

3. Dimensions

K	3.2 - 3.4 mm
KF	6.54 - 6.74 mm
MS	1.7 - 1.9 mm
BCS	3.8 - 4.0 mm
Pre-st.	- mm
Control lever angle	
α	19 - 27° deg
A	8.7 - 12.6 mm
β	34 - 44° deg
B	10.5 - 14.2 mm
γ	15 - 16° deg
C	7.9 - 9.5 mm

F21

ZEXEL - Test values
Injection pumps



F22

ZEXEL - Test values
Injection pumps



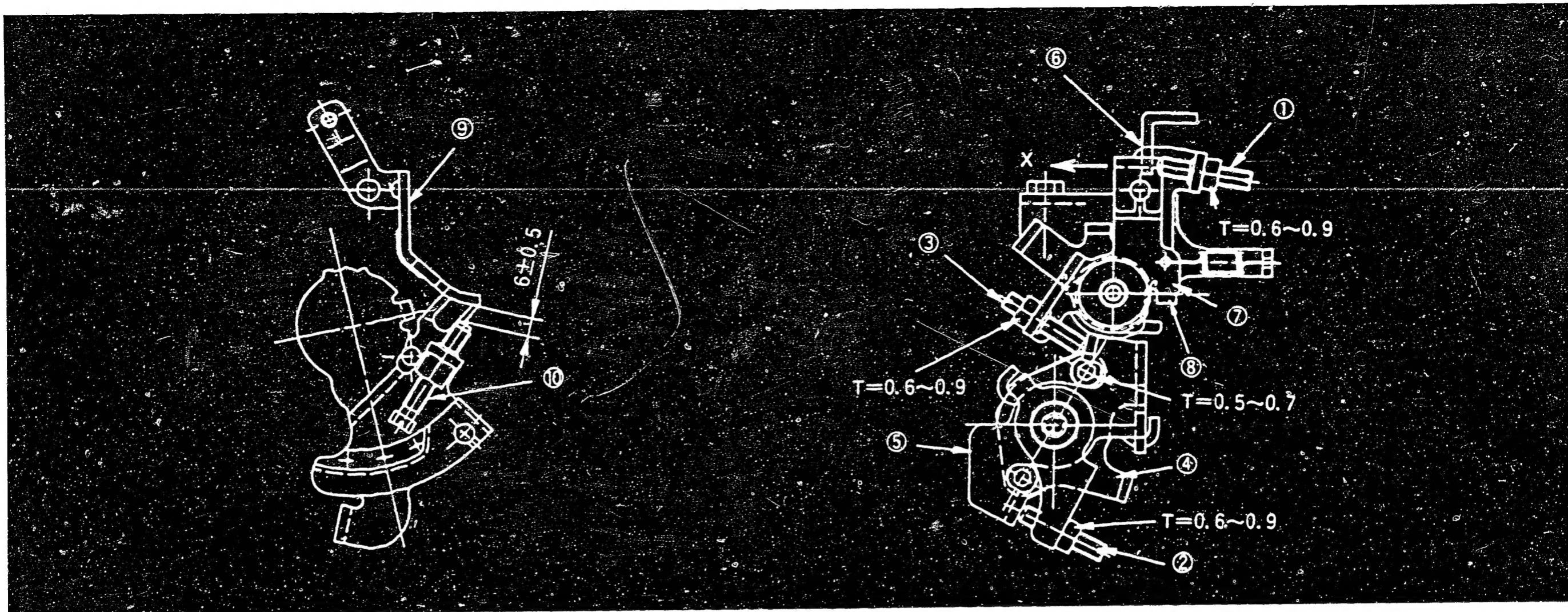

Figure 27

9 = Idling set bracket
10 = Screw

1 = Screw
2 = Screw
3 = Screw
4 = Stopper

5 = CSD lever
6 = Control lever
7 = Intermediate lever
8 = Stopper

104769-2190 2/4

■ M-CSD ADJUSTMENT

1. CSD Adjustment

- 1) Hold the control lever (6) in the idling position.
- 2) Move the CSD lever (5) to the right until it contacts the stopper (4).
- 3) Then, adjust the position of the screw (2) so that the timer stroke is 1.6 ± 0.2 mm and fix the screw (2) using the nut.

F23

ZEXEL - Test values
Injection pumps



F24

ZEXEL - Test values
Injection pumps



(Continued)

2. Fixing the Intermediate Lever Adjustment Screw

- 1) Hold the CSD lever (5) in the position described in item 1 (timer stroke: 1.6 ± 0.2 mm).
- 2) Move the intermediate lever (7) toward 'X' and confirm that it contacts the stopper (8).
- 3) Then, adjust the screw (3) so that the CSD lever (5) contacts the screw (3) and fix the screw (3) using the nut.
- 4) Return the intermediate lever (7) to its original position and confirm that the timer stroke is 0 mm.

3. Screw (1) Adjustment

- 1) Move the intermediate lever (7) toward 'X' until it contacts the stopper (8).
- 2) Adjust the position of the screw (1) so that the gap between the idling set bracket (9) and screw (10) is 6 ± 0.5 mm, and fix the screw (1) using the nut.
- 3) Then, confirm that the gap between the control lever (6) and screw (1) is approximately 1.7 mm.



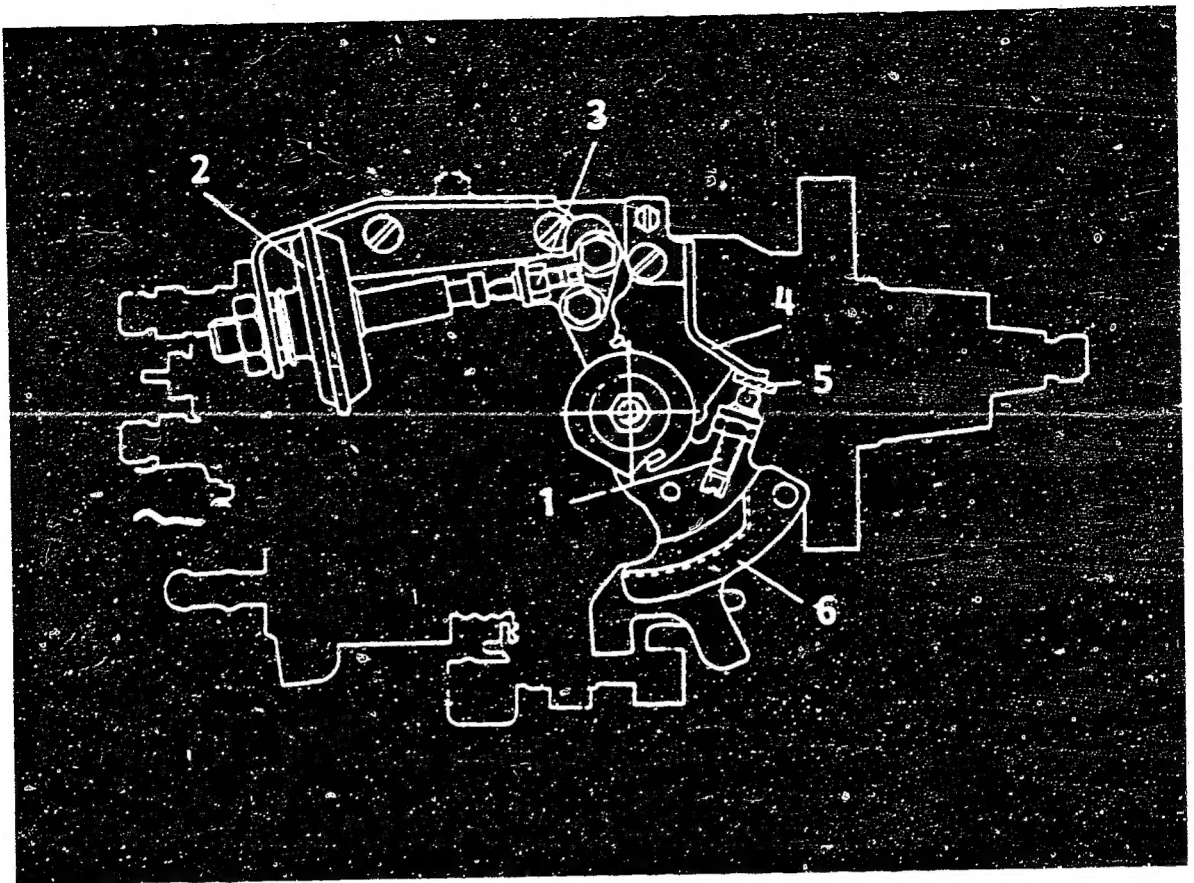

Figure 28

104769-2190 3/4

- | | |
|------------------------------|-------------------|
| 1 = Idling stopper bolt | 4 = Bracket |
| 2 = Dash pot | 5 = Block gauge |
| 3 = Dash pot adjusting screw | 6 = Control lever |

■ DASH POT ADJUSTMENT

1. Insert a block gauge (thickness gauge) of thickness 3.8 ± 0.05 mm in the gap between the idling stopper bolt and the bracket.
2. With the control lever positioned as described in 1. above, adjust the dashpot adjusting screw so that the dashpot adjusting screw and the pushrod are in contact.
Fix the screw using the nut.

Caution:

The adjusting screw and the pushrod must move together smoothly.

Confirm that the control lever returns to the idling position.



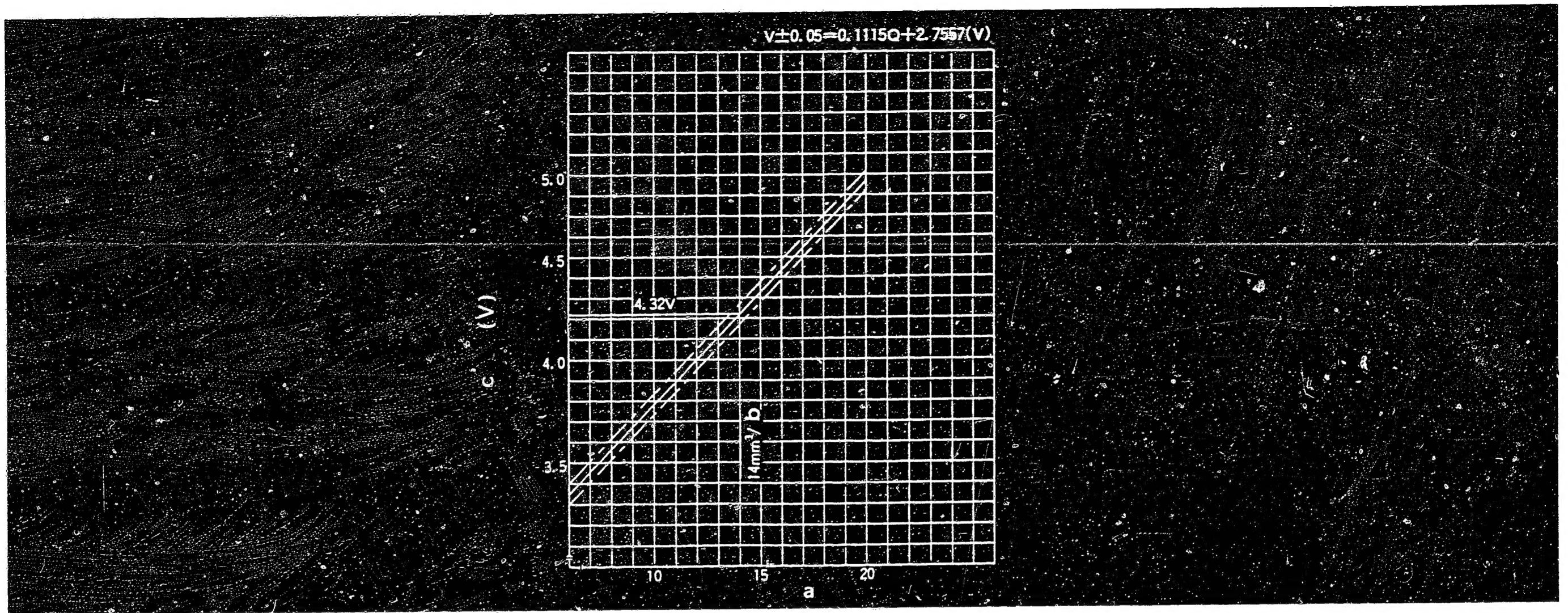

POTENTIOMETER ADJUSTMENT

Figure 29

a = Fuel injection quantity (cc/1000st)
 b = /stroke
 c = Out-put voltage

104769-2190 4/4

Under the following conditions, alter the potentiometer's installation position so that the out-put voltage equals the specified value.

Adjustment Conditions			Specified Value	Remarks
Control lever position	Pump speed (rpm)	Fuel injection quantity (cc/1000st)	Out-put voltage (V)	
approx. 15.5°	1200	Measure	Measure	Adjust. point
Idle	-	-	-	Check point
Full speed	-	-	-	Check point

* A control lever position of approx. 15.5° means that a block gauge of 8.4 mm thickness is inserted between the control lever and the idling stopper bolt.

(In-put voltage: 10V)

F27

ZEXEL - Test values
 Injection pumps



F28

ZEXEL - Test values
 Injection pumps

